



Burner management system

LMV6...

The LMV6 is a microprocessor-based unit with matching system components for controlling and supervision of forced draft burners of medium to large capacity.

The LMV6 and this data sheet are intended for original equipment manufacturers (OEMs) using the LMV6 in or on their products.

Notes



Attention!
All the safety, warning, and technical notes given in the basic documentation for the LMV6 (P7560) also apply to this document in full. Failure to observe this poses a risk of damaging the safety functions and the risk of electric shock.

Use

The LMV6 burner management system carries out all supervision tasks associated with medium to large-capacity forced draft burners, and features integrated communication interfaces that enable modular system extensions.

Flame supervision takes place with the following sensors:

Flame detectors	Continuous operation	Intermittent operation
ION	•	•
QRA2	---	•
QRA4	---	•
QRA7	•	•
QRA10	---	•
QRI	•	•

- Type-tested and approved in accordance with DIN EN 298

- Burner control
- Electronic ratio control
- Gas pressure switch valve proving
- Flue gas recirculation (FGR)
- Fault status messages counter
- Error history
- Restart counter
- Program stop function
- Forced intermittent operation (can be deactivated)
- Low-fire shutdown
- Alarm in case of start prevention
- Parameterizable program times and functions

The following items are integrated into the LMV6:

- Burner control complete with valve proving system
- Plug-in space for additional AGQ6.x
- Electronic fuel-air ratio control for a maximum of 5 actuators and VSD
- Flue gas recirculation (FGR): Started via time, temperature, mains input (thermostat) or temperature-compensated
- Green signal lamp (LED) for operating display *LMV6 live*

Supplementary documentation

Product type	Designation	Documentation type	Documentation number
LMV6	Burner management system	Environmental Product Declaration	E7560 *)
LMV60.110A2	Burner management system	Parameter list and error code list	I7560
LMV62.xxxA2	Burner management system	Parameter list and error code list	I7560
LMV6	Burner management system	Installation Guide	J7560
LMV60.110A2	Burner management system	Basic documentation	P7560
LMV62.xxxA2	Burner management system	Basic documentation	P7560
LMV6	Burner management system	Product range overview	Q7560

*) On request only



Note!

This document only refers to the product type – not the *product designation*. See the table below for details.

Product type	Product designation
AGG6.200A5	230 V AC power supply unit
AGG9	Connector set
AGQ6.3	Flame signal amplifier for QRA7 and QRI
AZL66	Display and operating unit
LMV6	Burner management system
QRA2	UV flame detector
QRA2M	UV flame detector
QRA4	UV flame detector
QRA7	UV flame detector
QRA10	UV flame detector
QRI	Infrared flame detector
SQM4	Actuators



Applied directives:

- Low Voltage Directive 2014/35/EU
- Gas Appliances Regulation (EU) 2016/426
- Directive for pressure devices 2014/68/EU
- Electromagnetic compatibility EMC (immunity) *) 2014/30/EU

*) The compliance with EMC emission requirements must be checked after the burner management system is installed in equipment

Compliance with the regulations of the applied directives is verified by the adherence to the following standards/regulations:

- Automatic burner control systems for burners and appliances burning gaseous or liquid fuels DIN EN 298
- Safety and control devices for gas burners and gas-burning appliances – Valve proving systems for automatic shutoff valves DIN EN 1643
- Safety and control devices for burners and appliances burning gaseous or liquid fuels – Control functions in electronic systems DIN EN 12067-2
Part 2:
Fuel-air ratio control/supervision of the electronic type
- Safety and control devices for burners and appliances burning gaseous and/or liquid fuels DIN EN 13611
- Automatic electrical controls for household and similar use EN 60730-2-5
Parts 2–5: Special requirements on automatic electric burner control and monitoring systems
- Automatic electrical controls for household and similar use DIN EN IEC 60730-2-14
Parts 2–14:
Particular requirements for electric actuators

The edition of the standards that applies in each case can be found in the declaration of conformity.



Note!
Household and similar electrical appliances – Safety
Part 2-102:
Particular requirements for gas, oil, and solid-fuel burning appliances having electrical connections. The electrical connections of the LMV6 comply with the requirements of EN 60335-2-102:2016.



EAC conformity (Eurasian compliance)



UKCA conformity mark (UK compliance)



China RoHS
Hazardous substances table:
<http://www.siemens.com/download?A6V10883536>



Disposal notes

The LMV6 contains electrical and electronic components and must not be disposed of together with domestic waste. Local and currently valid legislation must be complied with.

Open Source Software (OSS) declaration

Due to the license terms of the software we use, Siemens AG wishes to note that the OEM is obligated to provide the following license text for the end user in the documentation:

Open Source Software (OSS) declaration

Embedded in – or bundled with – the LMV6 are open source software (OSS) components and other third-party components identified below.

You may receive a copy of, distribute, and/or modify any open source code for the OSS component under the terms of their respective licenses, which may be GNU General Public License, the GNU Lesser General Public License, the Modified BSD License and the MIT license. In the event of conflicts between Siemens license conditions and the open-source software license conditions, the open-source software conditions take precedence with respect to the open-source software portions of the software.

You are permitted to modify proprietary components originating from Siemens and to engage in reverse engineering for purposes of debugging such modifications, to the extent such components are linked to libraries licensed under the GNU Lesser General Public License.

You are not permitted to distribute information resulting from this reverse engineering of the modified proprietary components. Your rights to modify proprietary components originating from parties other than Siemens are governed by the respective third-party license conditions.

On written request within three years from the date of product purchase and against payment of our expenses, Siemens will supply the source code for any OSS component identified below in line with the terms of the applicable license.

For this, please contact us at:

Siemens AG
Otto-Hahn-Ring 6
81739 Munich
Germany
Keyword: Open Source Request

“SIEMENS' warranty obligations are set forth in your agreement with SIEMENS. SIEMENS does not provide any warranty or technical support for this Product or any OSS components contained in it if they are modified or used in any manner not specified by SIEMENS. The license conditions listed below may contain disclaimers that apply between you and the respective licensor. In the case of lack of clarity, SIEMENS does not make any warranty commitment on behalf of or binding upon any third party licensor.”

All open source software components used within the product (including their copyright holders and the license conditions) can be found on the website at <http://www.siemens.com/download?A6V11985963>

The LMV6 has a designed lifetime* of 250,000 burner startup cycles which, under normal operating conditions in heating mode, corresponds to approx. 10 years of service (starting from the date of manufacture on the nameplate). This is based on the endurance tests specified in the DIN EN 298 standard. A summary of the conditions has been published by the European Control Manufacturers Association (Afecon) (www.afecor.org).

The designed lifetime is based on use of the LMV6 according to the manufacturer's data sheet and the basic documentation. After reaching the designed lifetime in terms of the number of burner startup cycles, or after the corresponding usage time, the LMV6 must be replaced by authorized personnel to continue to guarantee the availability of the plant.

* The designed lifetime is not the warranty time specified in the Terms of Delivery.



Note

250,000 burner startup cycles achieved

Once 250,000 burner startup cycles have been reached, the AZL66 display will show the following message: '>250,000 startups achieved. Replace LMV6 if error occurs constantly.' This message does not affect the operation of the LMV6. You can simply cancel this message to acknowledge it; however, it will reappear each time the power is turned on.

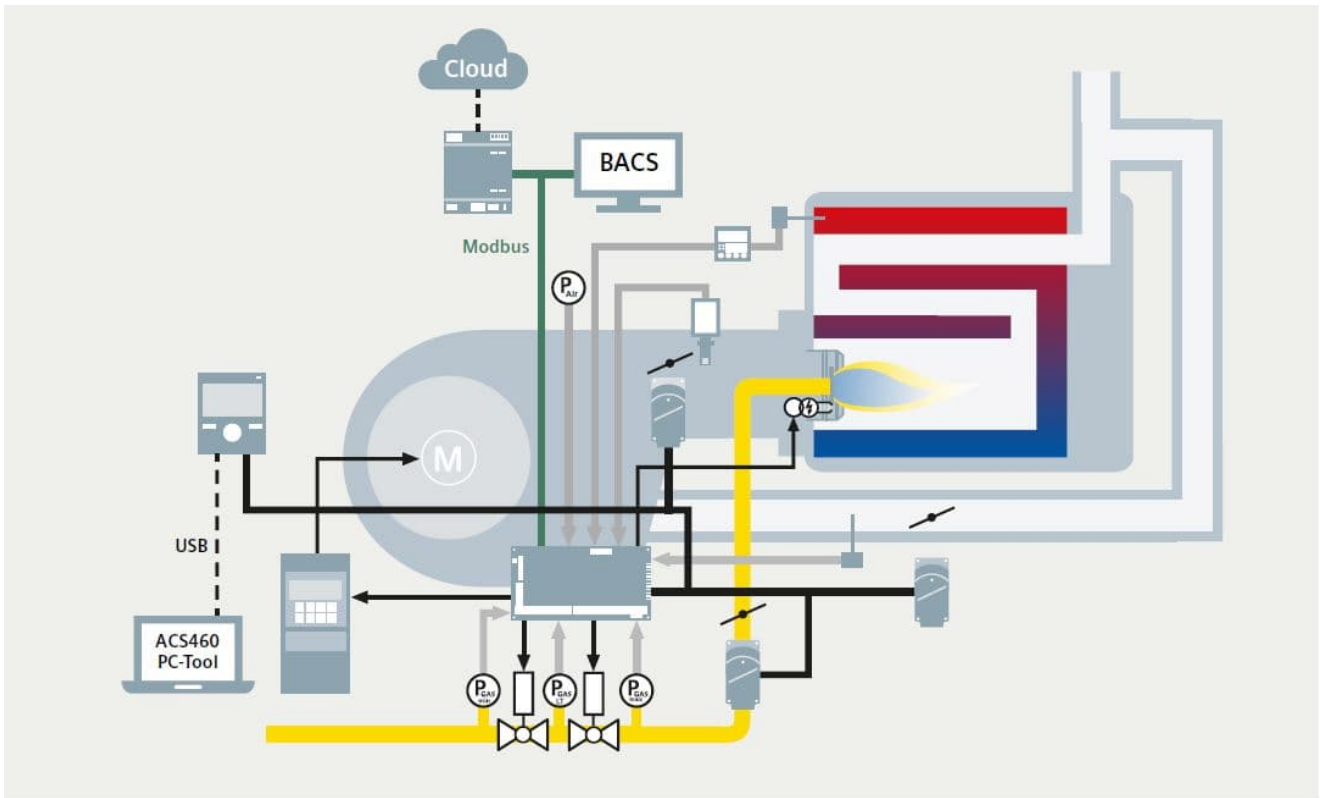

The system components for the LMV6 (e.g., AZL66) are connected directly to the LMV6 via the CAN bus. All safety-related digital inputs and outputs of the LMV6 are monitored via a contact-feedback network. The LMV6 is operated and parameterized via the AZL66. The AZL66 features menu-driven operation, offering straightforward operation and targeted diagnostics. When performing diagnostics, the operating statuses and type of error are communicated via the display as well as via the signal lamp (LED). The various parameterization levels of the burner/boiler manufacturer and heating engineer are password-protected against unauthorized access. Simple settings that the plant operator can make on site do not require a password.

Type summary

Burner management system The LMV6 is a microprocessor-based burner control with coordinated system components for controlling and monitoring forced draft burners of medium to large capacity.



All LMV6 systems are approved for intermittent operation and continuous operation in accordance with DIN EN 298.

Article no.	Type (ASN)	For forced draft gas burners	With dual-fuel operation	Max. number of actuators	With variable speed drive	With flue gas recirculation (FGR)		With load controller	With O2 control	Parameter set (country specific)	Mains voltage
						Temperature compensation					
						Without	With				
S55402-C403-A100	LMV60.110A2	●	---	3	---	●	---	---	---	EU	230 V AC
S55402-C402-A100	LMV62.110A2	●	---	4	●	●	---	---	---	EU	230 V AC
S55402-C404-A100	LMV62.111A2	●	---	4	●	---	●	---	---	EU	230 V AC
S55402-C406-A100	LMV62.710A2	●	---	5	●	●	---	---	---	EU	230 V AC
S55402-C407-A100	LMV62.711A2	●	---	5	●	---	●	---	---	EU	230 V AC



Note!

Details on the accessories and required system components can found in the LMV6 product range overview Q7560.

Individual connector set AGG6.7x0

Example:



Connection terminals	No. of poles	Unit	Function (Part A)	Individual connector set for...		
				LMV60	LMV62 LMV63	AGG6.200A5
				S55854-Z605-A100 AGG6.710	S55854-Z606-A100 AGG6.720	S55854-Z607-A100 AGG6.730
Quantities						

RAST5						
X51	3	LMV6	Flame detector	1	1	---
X52	5	LMV6	Flame detector	1	1	---
X61	3	LMV6	Gas pressure switch-min (Pmin)	1	1	---
X62	3	LMV6	Gas pressure switch-max (Pmax)	1	1	---
X63	2	LMV6	Valve proving (P LT)	1	1	---
X64	2	LMV6	Air pressure switch (LP)	1	1	---
X71	3	LMV6	Start release Burner flange	1	1	---
X72	4	LMV6	Fan (M) Operating lamp Start signal	1	1	---
X73	4	LMV6	Load controller (LR) Flue gas recirculation (FGR)	1	1	---
X81	3	LMV6	Safety valve (SV)	1	1	---
X82	3	LMV6	Ignition (Z)	1	1	---
X83	3	LMV6	Pilot valve (PV)	1	1	---
X84	3	LMV6	Fuel valve (V2)	1	1	---
X91	4	LMV6	Fuel valve (V1)	1	1	---
X92	3	LMV6	Alarm (AL) Reset (EK)	1	1	---
X93	5	LMV6	Power supply Safety loop (SK)	1	1	---
X161	3	AGG6.200A5	Power supply	---	---	1

Individual connector set AGG6.7x0 (continued)

Connection terminals	No. of poles	Unit	Function (Part B)	Individual connector set for...		
				LMV60	LMV62 LMV63	AGG6.200A5
				S55854-Z605-A100 AGG6.710	S55854-Z606-A100 AGG6.720	S55854-Z607-A100 AGG6.730
				Quantities		
RAST3.5						
X11	4	LMV6	CAN bus	1	1	--
X12	4	LMV6	CAN bus	1	1	--
X13	8	AGG6.200A5	CAN bus	--	--	1
X15	4	SQM4x	CAN bus	3	3	2
X16	4	SQM4x	CAN bus	3	3	2
X21	6	AGQ6.4	External flame safeguard	--	--	1
X22	6	LMV6	Modbus	--	1	--
X23	6	LMV6	Temperature sensor	--	1	--
X24	3	LMV6	Temperature sensor	--	1	--
X31	5	LMV6	Analog inputs 2 to 10 V, 4 to 20 mA, 24 V DC, setpoint changeover	--	1	--
X32	6	LMV6	Analog inputs 2 to 10 V, 4 to 20 mA	--	1	--
X33	2	LMV6	Output 4 to 20 mA	--	1	--
X34	3	LMV6	Fuel meter	--	1	--
X45	5	LMV6	Output: PWM fan motor	--	1	--
X46	6	LMV6	Variable speed drive	--	1	--
X47	2	LMV6	Output: 4 to 20 mA power supply, variable speed drive	--	1	--
X48	3	LMV6	Fuel meter	--	1	--
RAST3.81						
X14	4	AZL66	CAN bus	1	1	--

Technical data

Basic unit LMV6

Mains voltage	230 V AC -15% / +10%
Mains frequency	50 Hz $\pm 6\%$
External primary fuse (Si)	Max. 6.3 A, slow



Caution!

Risk of damage to the switching contacts!

If the external primary fuse (Si) or internal fuse (F1) is blown due to overload or short-circuit at the terminals, the LMV6 must be replaced.

Internal consumption	< 35 W, typically
Protection class	I, with parts according to II in accordance with EN 60730-1:2016
Degree of protection	IP00



Note!

The burner or boiler manufacturer must ensure degree of protection IP40 for the LMV6 in accordance with EN 60529:1991 + A1:2000 + A2:2013 through adequate installation.

Rated surge voltage Category III (IEC 60664-1:2020)	4 kV
• Creepage distances and air gaps	2.5 kV due to voltage limitation measures
Pollution degree	2 in accordance with EN 60730-1:2016
Software class	Class C in accordance with EN 60730-1:2016 / EN 60730-2-5:2015 + A1:2019
Permissible mounting position	Optional
Weight	Approx. 870 g
DIN rail	TH 35-7.5 in accordance with EN 60715:2017

Technical data (continued)

Terminal loading: *Inputs*

Mains supply: The input current for the power supply is dependent on the operating status of the LMV6

Rated voltage	UMains 230 V
---------------	--------------

- Safety shutdown from the operating position at mains voltage $\leq 185 \text{ V AC}$

- Restart is initiated when mains voltage exceeds $\geq 195 \text{ V AC}$

Status inputs (with the exception of the safety loop) of the contact feedback network are used for system supervision and require mains-related input voltage

- Safety loop Refer to *Terminal loading: Outputs*

- Contact material recommended for external signal sources (air pressure switch, gas pressure switch-min, gas pressure switch-max, etc.) Gold-plated silver contacts

- Transition / settling behavior / bounce

- Permissible bounce time of contacts when switching on/off Max. 20 ms (after the bounce time, the contact must stay closed or open)

- Inputs for voltage detection

- ON $> 160 \text{ V AC}$

- OFF $< 80 \text{ V AC}$

- Input currents 0.7 to 1.5 mA peak

Technical data (continued)

Terminal loading: *Outputs*

Total contact loading:

- | | |
|--------------------------------------|-----------------|
| • Rated voltage | 230 V AC, 50 Hz |
| • LMV6 input current and safety loop | Max. 5 A |

Note!

The input current at terminal X93 pin 5 also flows through safety loop terminal X93 pin 1 / pin 2. Fusing is provided via the unit fuse (F1) of the LMV6.



The components of the safety loop disconnect the energy supply to the following loads when tripped:

- Ignition transformer
- Fuel valves

Single contact loading:

Fan motor (M) terminal X72 pin 1

- | | |
|-----------------|------------------------------|
| • Rated voltage | 230 V AC, 50 Hz |
| • Rated current | 2 A |
| • Load factor | $\text{Cos}\varphi \geq 0.4$ |

Alarm (AL) terminal X92 pin 2

- | | |
|-----------------|------------------------------|
| • Rated voltage | 230 V AC, 50 Hz |
| • Rated current | 1 A |
| • Load factor | $\text{Cos}\varphi \geq 0.6$ |

Ignition transformer (Z) terminal X82 pin 3

- | | |
|-----------------|------------------------------|
| • Rated voltage | 230 V AC, 50 Hz |
| • Rated current | 2 A |
| • Load factor | $\text{Cos}\varphi \geq 0.2$ |

Fuel valve (V1) terminal X91 pin 4

Fuel valve (V2) terminal X84 pin 3

- | | |
|-----------------|------------------------------|
| • Rated voltage | 230 V AC, 50 Hz |
| • Rated current | 2 A |
| • Load factor | $\text{Cos}\varphi \geq 0.4$ |

Note!

Valve proving via fuel valve circuit!

With activated valve proving via fuel valve circuit

- | | |
|-----------------|------------------------------|
| • Rated current | 1 A |
| • Load factor | $\text{Cos}\varphi \geq 0.4$ |



Pilot valve (PV) terminal X83 pin 3

- | | |
|-----------------|------------------------------|
| • Rated voltage | 230 V AC, 50 Hz |
| • Rated current | 1 A |
| • Load factor | $\text{Cos}\varphi \geq 0.4$ |

Operating light terminal X72 pin 2

- | | |
|-----------------|------------------------------|
| • Rated voltage | 230 V~ 50 Hz |
| • Rated current | 1 A |
| • Load factor | $\text{Cos}\varphi \geq 0.6$ |

Variable speed drive (VSD)

All voltages	SELV
Release contact terminal X46 pin 1 / pin 2	
<ul style="list-style-type: none"> • Rated voltage • Rated current 	<p>24 V_{DC} (SELV) 5 mA to 0.5 A</p>
Alarm input terminal X46 pin 5	
<ul style="list-style-type: none"> • Rated voltage 	<p>Active: 12–24 V_{DC} Inactive: <4 V_{DC} Alarm ON or OFF adjustable via parameter 6015 (Variable speed drive (VSD): Alarm input logic)</p>
<ul style="list-style-type: none"> • Input impedance 	Approx. 2500 Ω
Analog output terminal X47 pin 1 / pin 2	
<ul style="list-style-type: none"> • Rated voltage • Rated current 	<p>Max. 24 V (with no load) 4–20 mA regulated, corresponds to 0–105% (→ speed standardization)</p>
<ul style="list-style-type: none"> • Output load 	Max. 550 Ω (load), short-circuit-proof
Speed input terminal X46	
Sensor supply terminal X46 pin 3 / pin 4	
<ul style="list-style-type: none"> • Rated voltage 	10–12 V _{DC}
	Max. 15 mA
Speed feedback X46 pin 4 / pin 6	
<ul style="list-style-type: none"> • Input impedance • Motor speed • 100% speed • Sensor 	<p>Approx. 2 kΩ 300 to 6300 rpm 1350 to 6300 rpm Inductive sensor according to DIN 19234 (Namur) or Open Collector (pnp) with U_{CEsat} <4 V, U_{CEmin} >15 V_{DC}</p>
<ul style="list-style-type: none"> • Cable length 	Max. 100 m (sensor cable must be laid separately)
<ul style="list-style-type: none"> • ON/OFF level <ul style="list-style-type: none"> ○ ON ○ OFF 	<p>≥4.2 V or I ≥2.1 mA (max. 12 V or 10 mA) ≤1 V or I <1 mA</p>

Note

Design of the cables!



Shielded cables are required for harsh industrial environments!

Cable lengths of up to 100 m are possible by fulfilling the voltage/current levels with defined ON/OFF levels (e.g., using a suitable sensor). The inductive sensor used must have double or reinforced insulation against the mains voltage.

Technical data (continued)

Cable lengths	Mains supply line	Max. 100 m (100 pF/m)
	Fan motor	Max. 50 m (100 pF/m), unshielded
	Pressure switch valve proving	Max. 50 m (100 pF/m), unshielded
	Remote lockout reset (laid separately)	Max. 50 m (100 pF/m), unshielded
	Alarm	Max. 50 m (100 pF/m), unshielded
	Air pressure switch	Max. 50 m (100 pF/m), unshielded
	Burner flange	Max. 50 m (100 pF/m), unshielded
	Safety loop	Max. 50 m (100 pF/m), unshielded
	Ignition transformer	Max. 50 m (100 pF/m), unshielded
	Gas pressure switch-max	Max. 50 m (100 pF/m), unshielded
	Gas pressure switch-min	Max. 50 m (100 pF/m), unshielded
	Load controller	Max. 50 m (100 pF/m), unshielded
	Fuel valve	Max. 50 m (100 pF/m), unshielded
	Pilot valve	Max. 50 m (100 pF/m), unshielded
	Variable speed drive control	Max. 50 m (100 pF/m), laid separately
	Speed input	Max. 50 m (100 pF/m), laid separately
	Analog load controller	Max. 50 m (100 pF/m), laid separately
	Flame detector	Refer to <i>Flame supervision</i> chapter
	SQM4	Refer to Data Sheet N7820
	AZL66	Refer to Data Sheet N7562

Specifications as per EN 60730-1:2016

Type of shutdown or interruption for each circuit

Shutdown with micro switch 1-pole

Mode of operation Type 2 B

Cross-sectional areas

The cross-sectional areas of the mains power lines (L, N, and PE) and, if required, the safety loop (safety temperature limiter, water shortage, etc.) must be sized for rated currents according to the selected external primary fuse. The cross-sectional areas of the other cables must be sized in accordance with the primary fuse for the LMV6 (max. 6.3 AT).

Minimum cross-sectional area	0.75 mm ² (single-core or multi-core in accordance with IEC 60364-5-52:2009)
------------------------------	--

Cable insulation must be suitable for the respective temperatures and environmental conditions.

Technical data (continued)

RAST3.5 connector

Mechanical data

Connection cross sections, conductor screw connection

- | | |
|--|--|
| • Stranded conductor, fine-wired (flexible) | Cross section
Min. 0.14 mm ²
Max. 1.5 mm ² |
| • Stranded conductor, fine-wired (flexible) with ferrule | Cross section
Min. 0.25 mm ²
Max. 1 mm ² |
| • Stripping length | Approx. 7 mm |
| • Screw tightening torque | 0.25 Nm |

Note!



AGG9 connector sets!

The AGG9 connectors of the connection cables for the LMV6 may only be removed or replaced when the plant is shut down (all-pole disconnection)!

RAST5 connector

Mechanical data

Insertion force / contact	≤4 N
Withdrawal force / contact	≥1 N
Tightening torque / screw	0.5 Nm in accordance with EN 60335-1
Contacting with blade connector	6.3 x 0.8 mm in accordance with IEC 61210:2010 Male multipoint connector in accordance with RAST5 standard

Connection cross sections, conductor screw connection

- | | |
|-----------------------------------|--|
| • Stranded conductor | Cross section max. 2.5 mm ² |
| • Stranded conductor with ferrule | Cross section max. 2.5 mm ² |
| • Stripping length | Approx. 8 mm |

Note!



AGG9 connector sets!

The AGG9 connectors of the connection cables for the LMV6 may only be removed or replaced when the plant is shut down (all-pole disconnection)!

Technical data (continued)

Environmental conditions



Warning!
Condensation, formation of ice, and ingress of water are not permitted. Failure to observe this poses a risk of damaging the safety functions and a risk of electric shock.

Climatic conditions

Storage

Temperature range -20 to +60°C

Humidity < 95% r.h.

Transport

Temperature range -20 to +60°C

Humidity < 95% r.h.

Operation

Temperature range -20 to +60°C

Humidity < 95% r.h.

Installation altitude Max. 2,000 m above sea level

Mechanical conditions

Vibration tests According to IEC 60068-2-6:2008 with acceleration of 10 m/s²

Shock tests According to IEC 60068-2-27:2010 with peak accelerations of 100 m/s²

Flame supervision with ionization probe

With LMV6 at terminal X52.



Warning!
Provide protection to prevent people from coming into contact with the ionization probe (risk of electric shock)!

Short-circuit current	Max. AC 850 µA
Permissible length of flame detector cable (laid separately)	10 m (100 pF/m), unshielded



Note!
Display on the AZL66 in the event of a short-circuit!
In the event of a short-circuit, a flame signal of approx. 12% is displayed on the AZL66.

	At mains voltage 230 V AC	Flame intensity
Detector voltage between ionization probe and ground (AC voltmeter $R_i \geq 10 \text{ M}\Omega$)	Approx. 230 V AC	---
Switching threshold (limit values):		
Switching on (flame ON) (DC ammeter $R_i \leq 5 \text{ k}\Omega$)	3 µA	25%
Start prevention due to extraneous light	---	18%
Recommended flame intensity for reliable operation	---	> 40%
Switching threshold in the event of poor flame during operation	---	Approx. 30%
Possible detector current with flame (typical)	> 15 µA	100%
Maximum detector current	60 µA DC	---



Note!
As the detector line capacitance (detector line length) increases, the voltage at the ionization probe – and thus the detector current – will drop. Long line lengths and very high-ohmic flames may necessitate the use of a low-capacitance detector cable. In spite of special electronic circuits designed to compensate possible adverse effects of the ignition spark on the ionization current, it is important to ensure that the minimum detector current required is already available during the ignition phase. If this is not the case, the primary ignition transformer connections must be interchanged and/or the electrodes relocated.

Technical data (continued)

Connection diagram

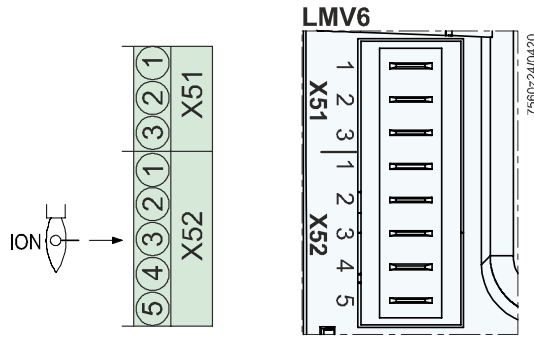

Measuring circuit for detector current measurement

Ionization probe

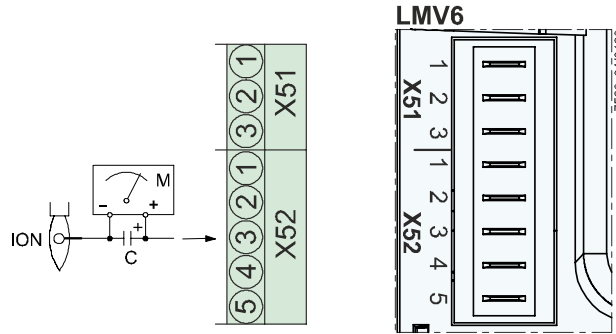

Legend

- C Electrolytic capacitor 100 to 470 μ F; 10 to 25 V DC
- ION Ionization probe
- M Micro-ammeter R_i max. 5000 Ω

Flame supervision with
QRA2 / QRA2M / QRA4 /
QRA10



Caution!

If QRA2 / QRA2M / QRA4 / QRA10-UV tubes are used for flame supervision on the LMV6, it must be ensured that the LMV6 is permanently connected to power (DIN EN 298), thus enabling the LMV6 to detect flame detector failures during startup and shutdown. The LMV6 generally operates with QRA in intermittent operation. For *Technical data*, refer to Data Sheet N7712, UV flame detector QRA2 / QRA2M / QRA10! For *Technical Data*, refer to Data Sheet N7711, UV flame detector QRA4!

Notes

Lifetime of the UV cell.

UV cells and the QRA2/QRA4/QRA10 are subject to wear and tear and must be replaced as part of regular maintenance, at the latest at the end of the average lifetime of the UV cell. The lifetime of the UV cell corresponds to approx. 10,000 hours at a maximum of +50°C; higher ambient temperatures reduce the lifetime considerably.

For details, refer to chapter *Technical data* in data sheet N7712 for the QRA2/QRA10. For details, refer to chapter *Technical data* in data sheet N7711 for the QRA4.

Operating voltage in operation	Max. 350 V peak
Possible detector current in operation	Max. 80 µA
Permissible length of the standard detector cable (laid separately)	Max. 10 m

Threshold values when flame is supervised by QRA

- Start prevention (extraneous light) Flame intensity $\geq 18\%$
- Operation Flame intensity $> 25\%$

For more detailed information on QRA2 / QRA2M / QRA10, refer to Data Sheet N7712. For more detailed information about QRA4, refer to data sheet N7711.

Connection diagram
QRA2 / QRA2M / QRA4
/ QRA10

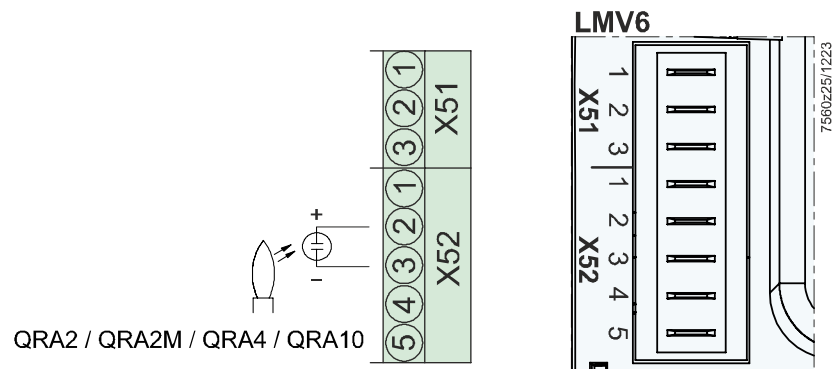

**Flame supervision with
QRA2 / QRA2M / QRA4 /
QRA10**

Measuring circuit for
detector current
measurement

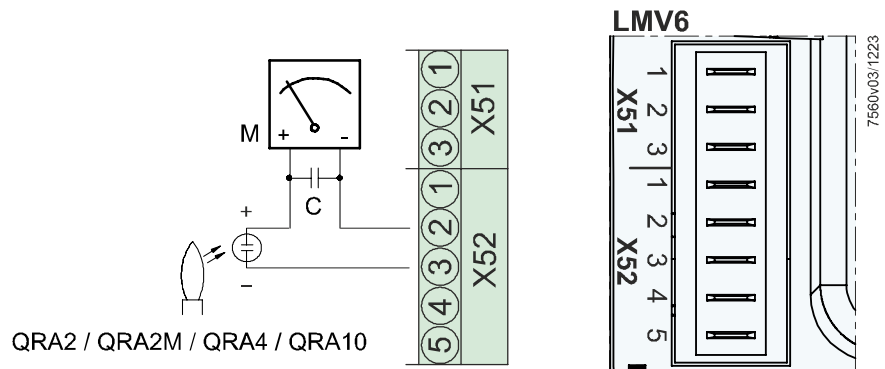

Legend

C Electrolytic capacitor 100 to 470 μ F; 10 to 25 V DC

M Micro-ammeter R_i max. 5000 Ω



Warning!

Simultaneous operation of the ionization probe and QRA2 / QRA2M / QRA4 / QRA10 is not permitted. Failure to observe this information poses a risk of damaging the safety functions.

Technical data (continued)

Flame supervision QRA7 with AGQ6.3

The QRA7 is suitable for continuous operation.

Supply voltage	
• QRA73A27	230 V~
• QRA75A27	230 V~
Supply voltage tested by increasing the supply voltage for the QRA7 (terminal X51 pin 3)	From 14 V $\overline{\text{--}}$ to 21 V $\overline{\text{--}}$
Required signal voltage (terminal X51 pin 2)	Min. 3.5 V DC $\overline{\text{--}}$ Flame display approx. 50% (with factory setting) – parameter number and % display must be checked in the respective application
Possible signal voltage (terminal X51 pin 2)	Max. 5.5 V $\overline{\text{--}}$ Flame display approx. 100% (with factory setting) – parameter number and % display must be checked in the respective application
Permissible signal voltage during the extraneous light test (terminal X51 pin 2)	Max. 0.3 V $\overline{\text{--}}$
Permissible length of detector cable	
• 6-core cable	Max. 10 m (signal line and supply line laid separately)
• Supply line no. 1, 2, and PE	Max. 100 m (separate from signal line)
• Signal line no. 3, 4, and 5	Max. 100 m (laid separately from 'L', 'N' and 'PE' as a shielded cable)

QRA7 connection diagram

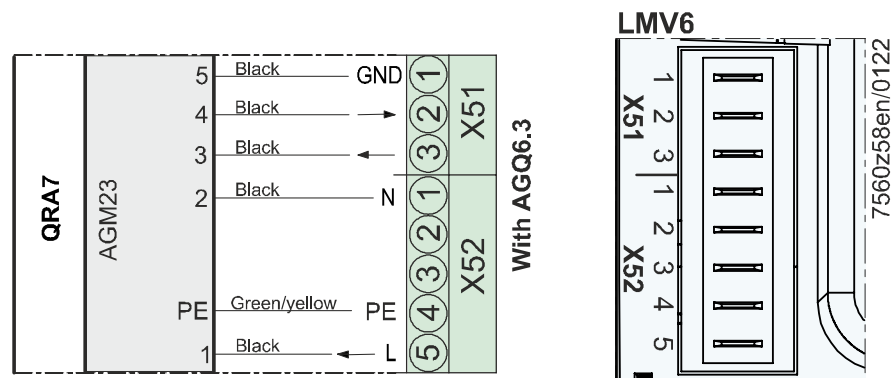

For more detailed information about QRA7, refer to data sheet N7712.

Technical data (continued)

**Flame supervision
QRI with AGQ6.3**

The QRI is suitable for continuous operation.

Supply voltage in operation/test (terminal X51 pin 3)	Approx. 14 V _{DC} / 21 V _{AC}
Required signal voltage (terminal X51 pin 2)	Min. 3.5 V DC _{AC} Flame display approx. 50% (with factory setting) – parameter number and % display must be checked in the respective application
Possible signal voltage (terminal X51 pin 2)	Max. 5.5 V _{AC} Flame display approx. 100% (with factory setting) – parameter number and % display must be checked in the respective application
Permissible signal voltage during the extraneous light test (terminal X51 pin 2)	Max. 0.3 V _{AC}
Permissible length of detector cable • Signal line	Max. 100 m (laid separately from 'L', 'N' and 'PE' as a shielded cable)

QRI connection diagram

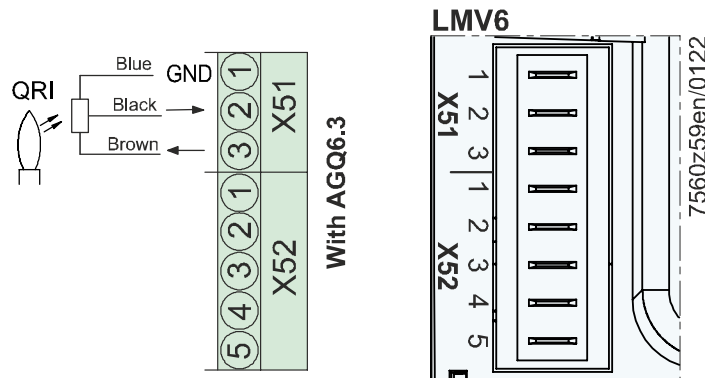

Measuring circuit for detector voltage measurement

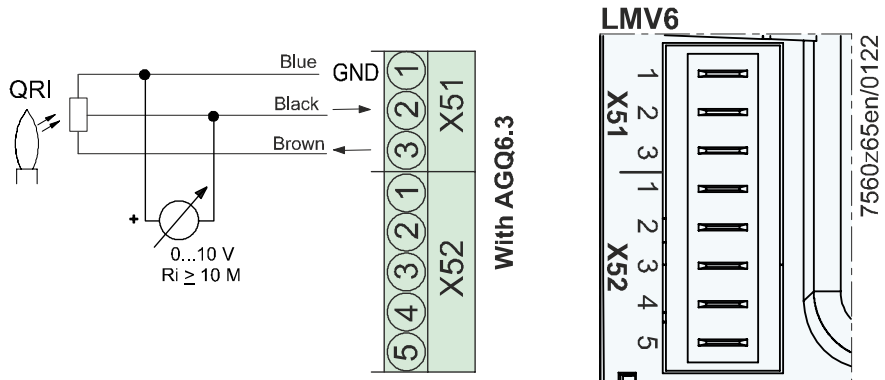

For more detailed information about QRI, refer to data sheet N7719.

Technical data (continued)

AGG6.200A5

Mains voltage	230 V AC -15%/+10%
Mains frequency	50 Hz \pm 6%
External primary fuse (Si)	Max. 6.3 A, slow
Output load	Max. 1.25 A / 30 W
Internal consumption	< 35 W, typically
Safety class	I, with parts according to II in accordance with EN 60730-1:2016
Degree of protection	IP00



Note
The burner or boiler manufacturer must ensure degree of protection IP40 for the AGG6.200A5 in accordance with EN 60529:1991 + A1:2000 + A2:2013 through adequate installation.

Rated surge voltage Category III (IEC 60664-1:2020)	4 kV
• Creepage distances and air gaps	2.5 kV due to voltage limitation measures
Degree of contamination	2 in accordance with EN 60730-1:2016
Permissible mounting position	Optional
Weight	Approx. 400 g
DIN rail	TH 35-7.5 in accordance with EN 60715:2017

Environmental conditions



Warning!
Condensation, formation of ice, and ingress of water are not permitted. Failure to observe this poses a risk of damaging the safety functions and a risk of electric shock.

Climatic conditions

Storage

Temperature range	-20 to +60°C
Humidity	< 95% r.h.

Transport

Temperature range	-20 to +60°C
Humidity	< 95% r.h.

Operation

Temperature range	-20 to +60°C
Humidity	< 95% r.h.
Installation altitude	Max. 2,000 m above sea level

Mechanical conditions

Vibration tests	According to IEC 60068-2-6:2008 with acceleration of 10 m/s ²
Shock tests	According to IEC 60068-2-27:2010 with peak accelerations of 100 m/s ²

Assignment of terminals

LMV60.110A2

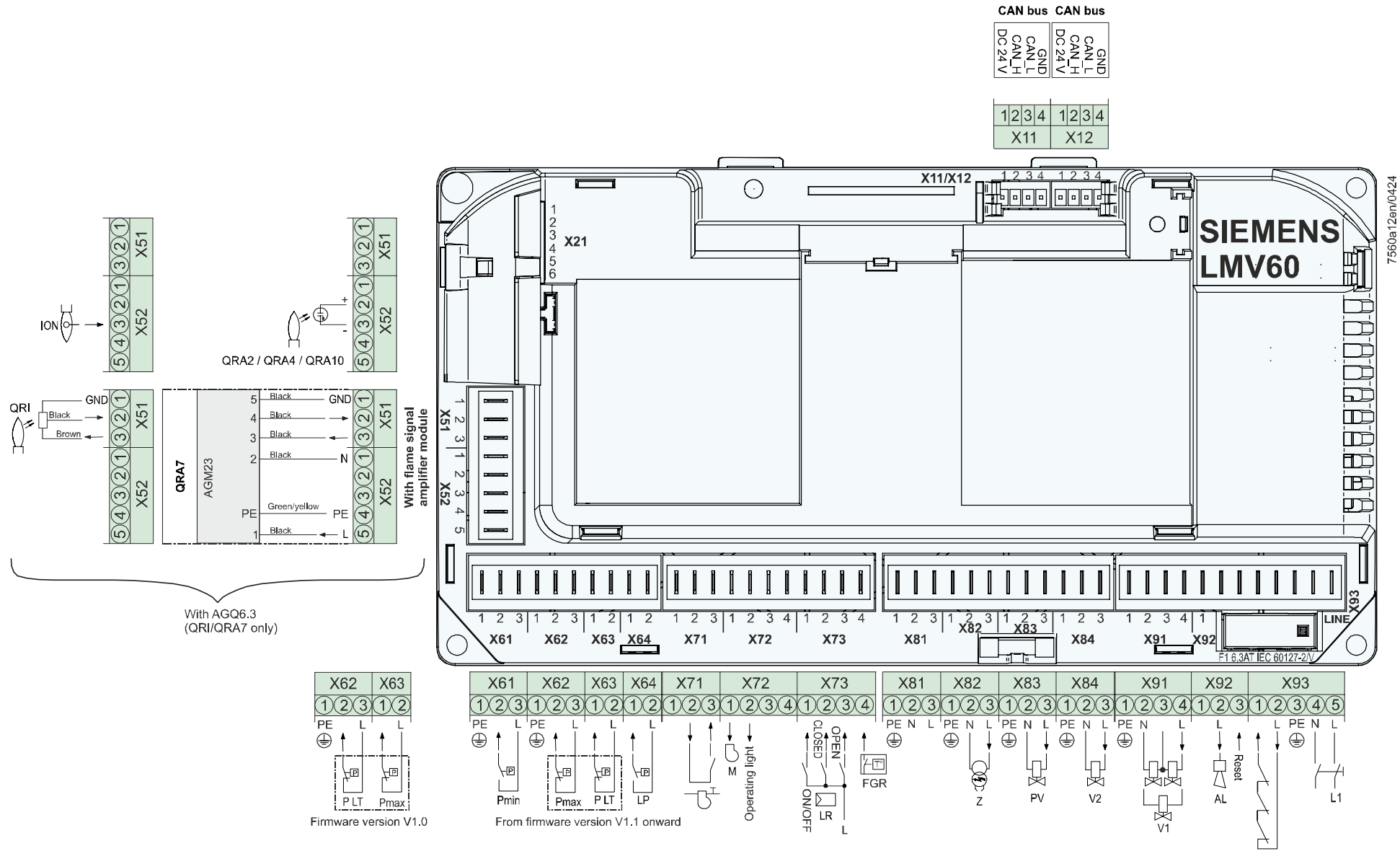

Assignment of terminals (continued)

LMV62 assignment of terminals 1

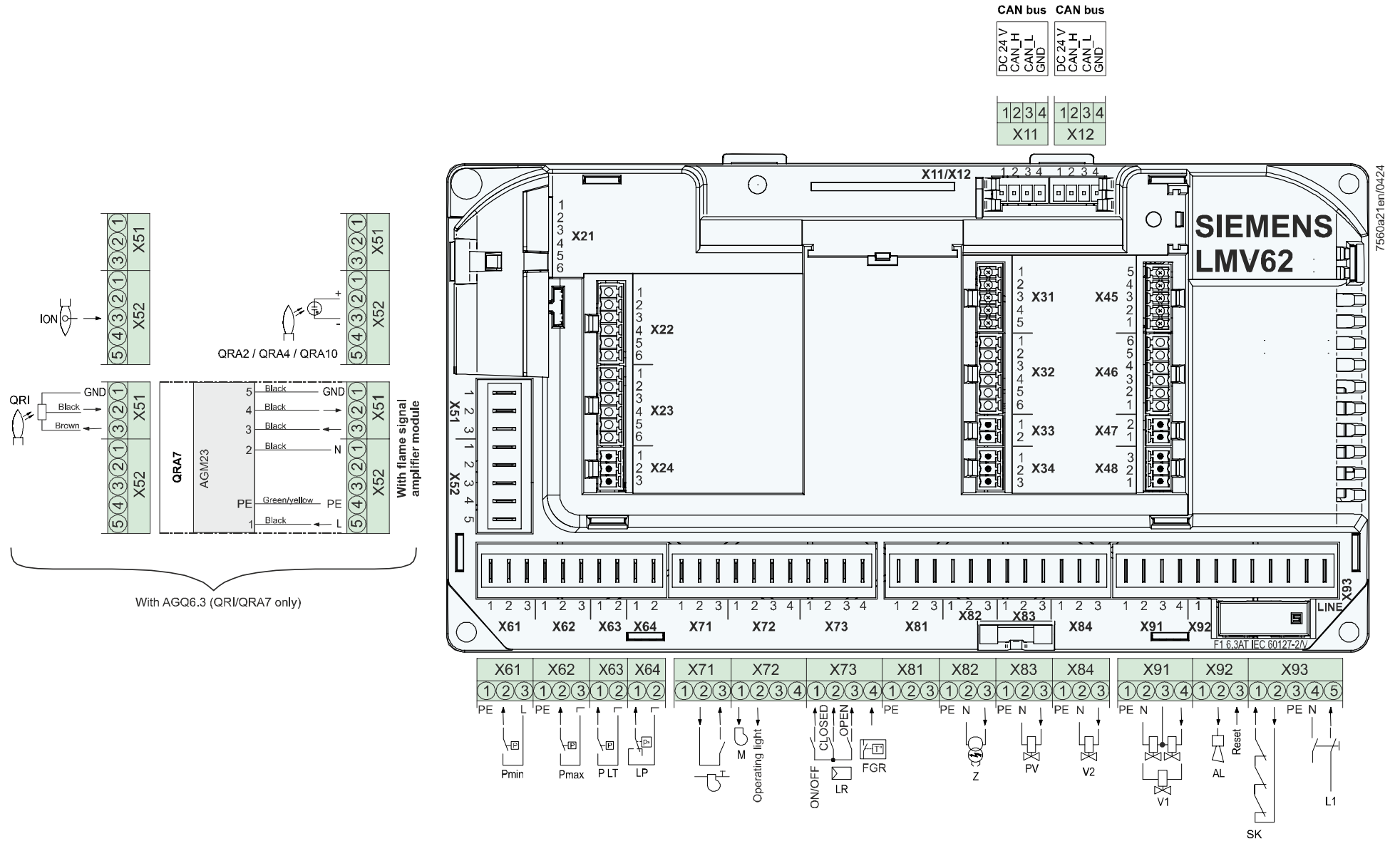

LMV62 assignment of terminals 2

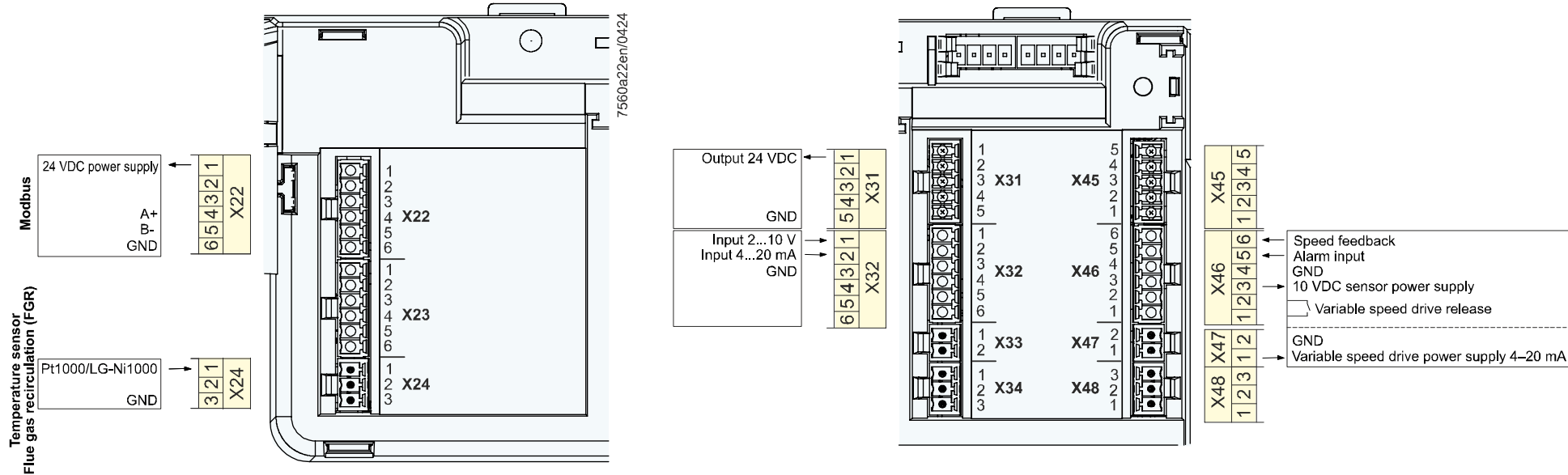

Legend

AGQ6.3	Flame signal amplifier
AL	Alarm device
FGR	Flue gas recirculation
ION	Ionization probe
L	Power supply 230 V AC
L1	Input phase 230 V AC
LP	Air pressure switch
LR	Load controller
LR-OPEN	Load controller OPEN position (increase load)
LR-CLOSED	Load controller CLOSED position (reduce load)
M	Fan motor
P LT	Pressure switch valve proving
Pmax	Pressure switch-max
Pmin	Pressure switch-min
PV	Pilot valve
QRA	UV flame detector
QRI	Infrared flame detector
SK	Safety loop
V1	Fuel valve
V2	Fuel valve
Z	Ignition transformer

Dimensions

Dimensions in mm

LMV6

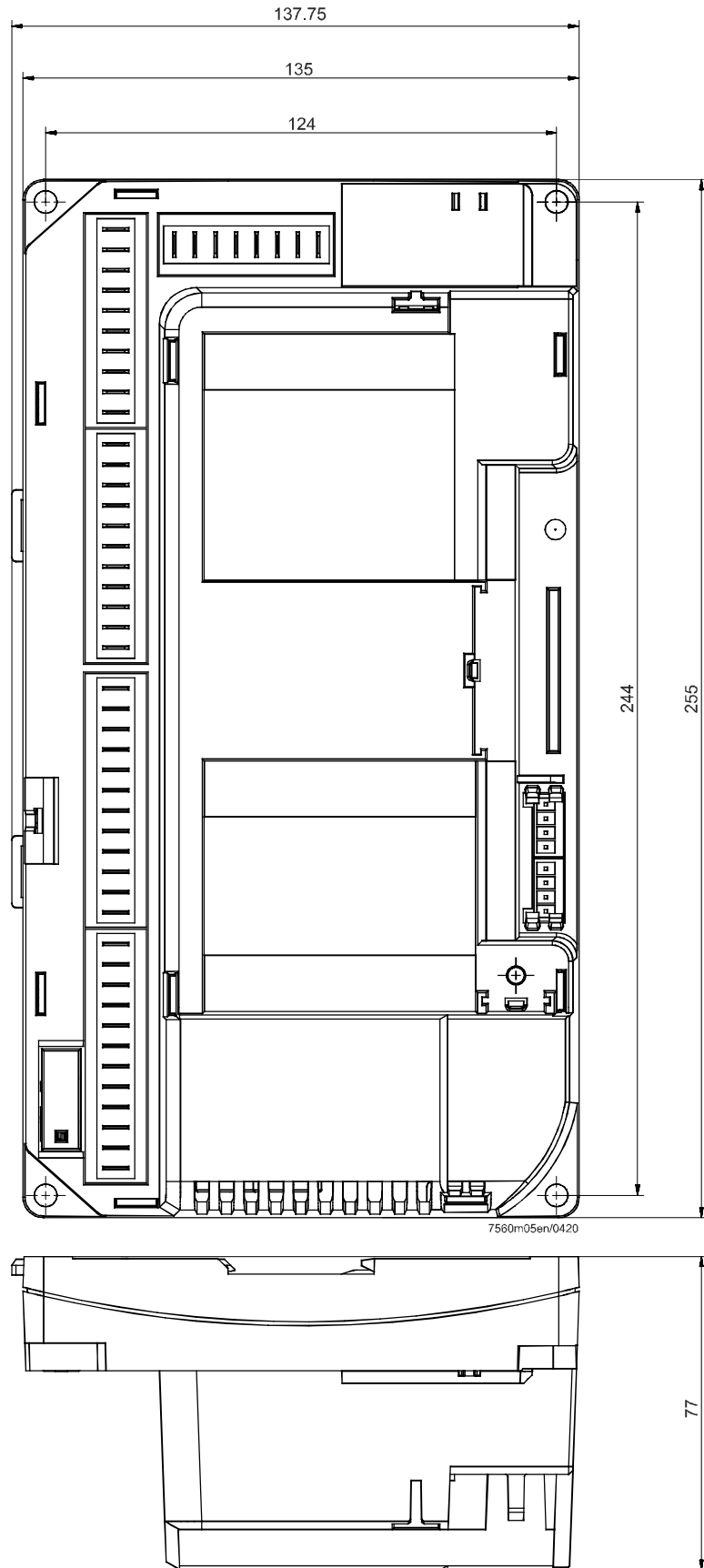

Dimensions (continued)

Dimensions in mm

AGG6.200A5 with X13 connector

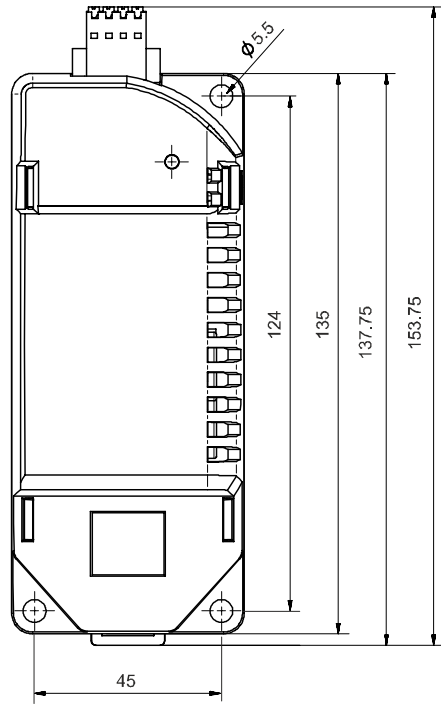
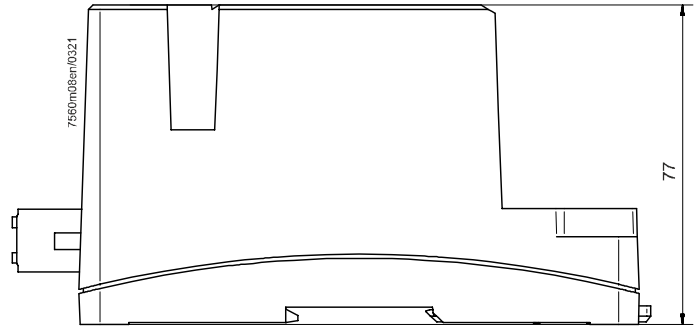
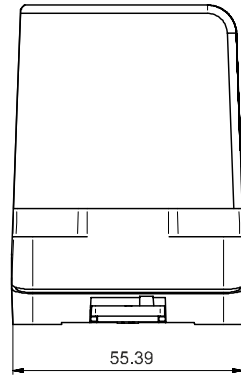

Dimensions in mm

AGQ6.3

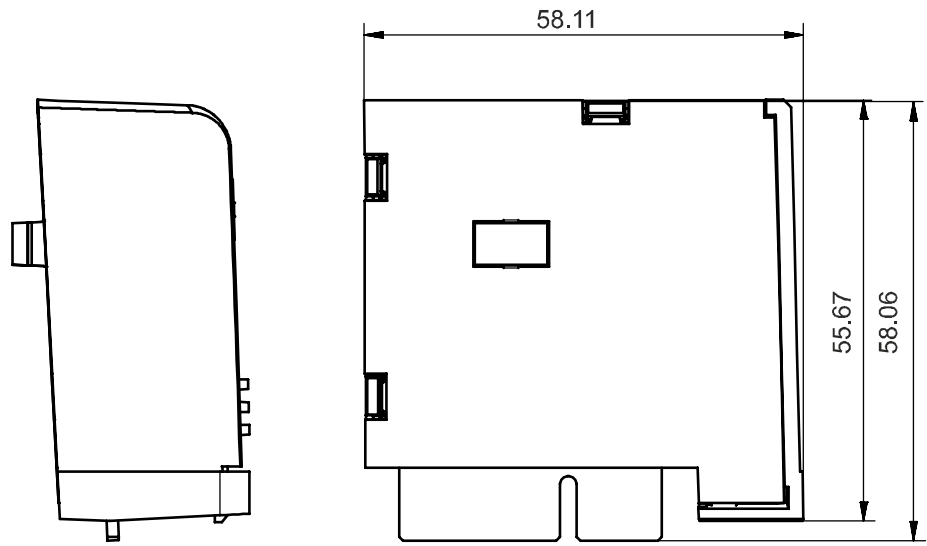

7560m09en/0122

