



## Gas burner controls

## LME39...

Burner controls for the supervision of 1- or 2-stage gas or gas burners of small to medium capacity, with or without fan in intermittent operation.

The LME39 and this Data Sheet are intended for use by OEMs which integrate the burner controls in their products.

### Use, features

Use	<p>LME39 are used for the startup and supervision of 1- or 2-stage gas or gas burners in intermittent operation. The flame is supervised with an ionization probe or a QRA2 / QRA2(1) / QRA2(2) / QRA2.9 / QRA4.U / QRA10.C UV flame detector with an AGQ3.xA27 ancillary unit for forced draft gas burners.</p> <ul style="list-style-type: none"> <li>• Applications in accordance with EN 267: Forced draft burner for gaseous fuels</li> <li>• Type-tested and approved in accordance with DIN EN 298</li> </ul>
Features	<ul style="list-style-type: none"> <li>• Undervoltage detection</li> <li>• Air pressure supervision with function check of the air pressure switch during startup and operation (depending on the respective parameterization)</li> <li>• Electrical remote reset facility</li> <li>• Multicolor indication of fault status and operational status messages</li> <li>• Limitation of restarts</li> <li>• Accurate program sequences thanks to digital signal handling</li> <li>• Controlled intermittent operation after a maximum 24 hours of continuous operation</li> <li>• BC interface</li> </ul>

## Supplementary documentation

Product type	Type of document	Document number
LME	Environmental declaration	E7101 *)
LME	Product range overview	Q7101
LME39	Basic Documentation	P7106

\*) Only on request

## Note



### Warning!

All safety, warning and technical notes given in the Basic Documentation of the LME39 (P7106) also apply to this document! If this is not observed, there is a risk of loss of safety functions and a risk of electric shock.

## Standards and certificates



### Applied directives:

- Low-voltage directive 2014/35/EC
- Directive for pressure devices 2014/68/EU
- Gas Appliances Regulation (EU) (EU) 2016/426
- Electromagnetic compatibility EMC (immunity) \*) 2014/30/EC

\*) The compliance with EMC emission requirements must be checked after the burner control is installed in equipment

Compliance with the regulations of the applied directives is verified by the adherence to the following standards / regulations:

- Automatic burner control systems for burners and appliances burning gaseous or liquid fuels DIN EN 298
- Safety and control devices for burners and appliances burning gaseous and/or liquid fuels – General requirements DIN EN 13611
- Automatic electrical controls Part 2-5: Particular requirements for automatic electrical burner control systems DIN EN 60730-2-5

**The relevant valid edition of the standards can be found in the declaration of conformity!**



### Note on DIN EN 60335-2-102

Household and similar electrical appliances – Safety Part 2-102:

Particular requirements for gas, oil and solid-fuel burning appliances having electrical connections. The electrical connections of the LME39 and the AGK11.6 plug-in base comply with the requirements of DIN EN 60730-2-5.



EAC Conformity mark (Eurasian Conformity mark)



UKCA conformity mark (UK)



China RoHS

Hazardous substances table:

<http://www.siemens.com/download?A6V10883536>



## Life cycle

Burner controls have a designed lifetime\* of 250,000 burner startup cycles which, under normal operating conditions in heating mode, correspond to approx. 10 years of usage (starting from the production date given on the type field). This lifetime is based on the endurance tests specified in standard EN 298. A summary of the conditions has been published by the European Control Manufacturers Association (Afecor) ([www.afecor.org](http://www.afecor.org)).

The designed lifetime is based on use of the burner controls according to the manufacturer's Data Sheet and Basic Documentation. After reaching the designed lifetime in terms of the number of burner startup cycles, or the respective time of usage, the burner control is to be replaced by authorized personnel.

\* The designed lifetime is not the warranty time specified in the Terms of Delivery

## Disposal notes

The LME39 contains electrical and electronic components and must not be disposed of together with domestic waste. Local and currently valid legislation must be observed.

## System overview

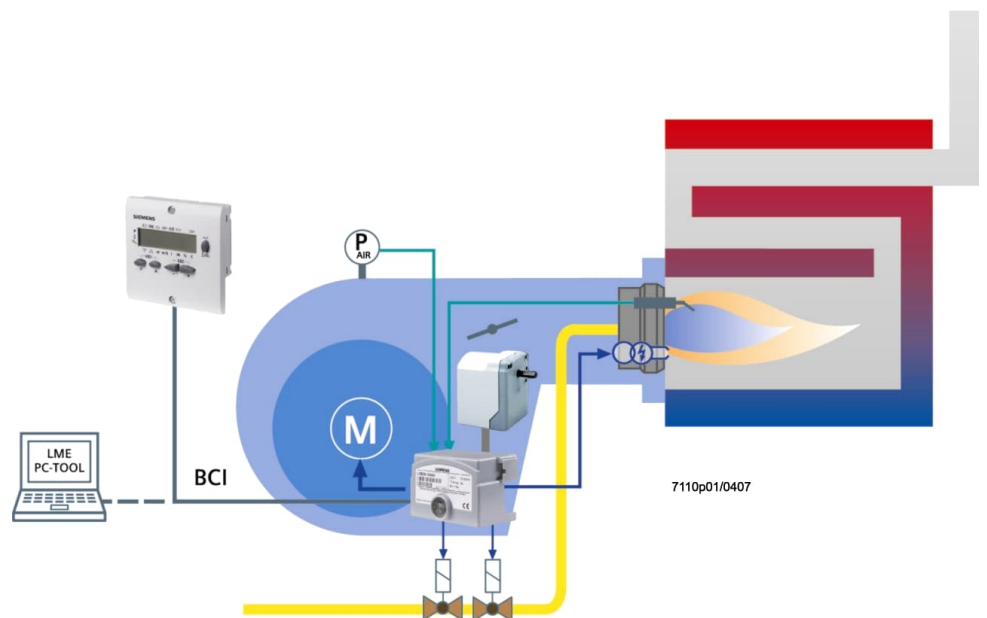

Example: Modulating gas burner

The diagram shows the maximum functionality of the system. The actual functions are to be determined based on the respective execution / configuration!

**Type summary** (other types on request)

The type reference given below applies to the LME39 without plug-in base and without flame detector. For ordering information on plug-in bases and other accessories, see *Accessories*.

Article no.	Type		Times in seconds												
			tw max. s	TSA max. s	tfz (P228) approx. s	t1 (P225) min. s	t1' (P256) min. s	t3 (P226) approx. s	t3n (P257) approx. s	t4 (P230) approx. s	t8 (P234) min. s	t10 (P224) approx. s	t11 (P259) min. s 1)	t12 (P260) min. s 1)	t22 (P231) max. s
<b>BPZ:LME39.100C1</b>	<b>LME39.100C1</b>	Requirement	2.5	3	0.3	30	---	3	2.5	10	0	180	30	30	---
<b>BPZ:LME39.100C2</b>	<b>LME39.100C2</b>	Requirement	2.5	3	0.3	30	---	3	2.5	10	0	180	30	30	---
	Setting range	Min.	---	0.3	0	0	---	1.2	0 + 0.3	1.2	0	0	0	0	---
		Max.	---	37.5 + 1.5 + 0.3	1.5	75	---	37.5	37.5 + 0.3	75	1237	179.5	75	75	---
		Increments (s)	---	0.147	0.147	0.294	---	0.147	0.147	0.294	4.851	4.851	0.294	0.294	---
		Factory setting	---	t3n + tfz	0.294	32.34	---	3.234	2.205 + 0.3	9.996	0	179.487	32.34	32.34	---
<b>BPZ:LME39.400C1</b>	<b>LME39.400C1</b>	Requirement	2.5	5	0.3	---	14.5	1.7	4.4	10	0	---	---	---	5
<b>BPZ:LME39.400C2</b>	<b>LME39.400C2</b>	Requirement	2.5	5	0.3	---	14.5	1.7	4.4	10	0	---	---	---	5
	Setting range	Min.	---	0.3	0	---	0	1.2	0	1	0	---	---	---	0
		Max.	---	37.5 + 1.5 + 0.3	1.5	---	75	37.5	37.5 + 0.3	75	1237	---	---	---	7.4
		Increments (s)	---	0.147	0.147	---	0.294	0.147	0.147	0.294	4.851	---	---	---	0.147
		Factory setting	---	t3n + tfz	0.294	---	15.582	1.911	4.116 + 0.3	9.996	0	---	---	---	4.557

**Function parameter**

**Parameter number**

**Factory setting**

Restart limitation value: 'Loss of flame and no flame at end of safety time (TSA)'

- 0 = no restart
- 1 = no restart
- 2 = 1 x restart
- 3 = 2 x restart
- 4 = 3 x restart

240

1



**Warning!**

The safety time (TSA) is a maximum of 40 seconds in the factory setting. The applicable standards for use in the respective application must be observed.

## Type summary (other types on request)

### Note on parameterization:

The exact value of the desired time (multiple of the increment of 0.147 seconds, 0.294 seconds, or 4.851 seconds) is always set using the AZL2 display and operating unit or ACS410 PC software. When parameterizing minimum or maximum times, the possibility of a  $\pm 7\%$  tolerance must be taken into consideration.

For **minimum** values: The value to be parameterized must be at least 7% **greater**. For **maximum** values: The value to be parameterized must be at least 7% **smaller**.

Example: Prepurge time shall be set to 30 seconds

Calculation: 30 seconds + 7% = 32.1 seconds

Value to be parameterized (parameter 225): Must be equal to or **greater** than the calculated value (e.g. 32,34 seconds)

Example: Safety time (TSA) shall be set via the change of postignition time to 5 seconds

Special case here: Safety time (TSA) is set directly via the change of postignition time and flame detection time using the following formula:

$$\text{TSA} = t3n + tfz = \text{parameter 257} + 0.3 \text{ seconds} + \text{parameter 228}$$

Calculation: 5 seconds - 7% = 4.65 seconds

$$t3n = 4.65 \text{ seconds} - 0.3 \text{ seconds} - \text{parameter 228}$$

$$t3n = 4.05 \text{ seconds (with } tfz = 0.3 \text{ seconds)}$$

Value to be parameterized (parameter 257): Must be equal to or **smaller** than the calculated value (e.g. 3.969 seconds)



Legend	tfz	Flame detection time	t4	Interval between ignition OFF and release fuel valve V2
	TSA	Safety time	t8	Postpurge time
	tw	Waiting time	t10	Specified time for air pressure signal
	t1	Prepurge time	t11	Programmed opening time for actuator
	t1'	Purge time	t12	Programmed closing time for actuator
	t3	Preignition time	t22	2nd safety time
	t3n	Postignition time (parameter 257 + 0.3 seconds)		

1) Maximum running time available for actuator. The actuator's running time must be shorter, otherwise, the actuator will not reach the required position

## Accessories (to be ordered separately)

---

### Connection accessories for small burner controls

#### **AGK11.6**

Article no.: **BPZ:AGK11.6**

For connecting the small-capacity burner controls to the burner plant.

Refer to Data Sheet N7201



#### Cable holder **AGK66**

Article no.: **BPZ:AGK66**

For plug-in base AGK11.6.

Refer to Data Sheet N7201



#### Cable gland holder **AGK65**

Article no.: **BPZ:AGK65**

- Cable gland holder for AGK11.6 plug-in base
- Pg11

Refer to Data Sheet N7201



#### Cable gland holder **AGK65.1**

Article no.: **BPZ:AGK65.1**

- Cable gland holder for AGK11.6 plug-in base
- M16 x 1.5

Refer to Data Sheet N7201



---

### Flame detector

#### UV flame detector **QRA2 / QRA2(1) / QRA2(2) / QRA2.9**

Only in conjunction with ancillary unit AGQ3.xA27.

Refer to Data Sheet N7712



#### UV flame detector **QRA4.U**

Only in conjunction with ancillary unit AGQ3.xA27.

Refer to Data Sheet N7711



#### UV flame detector **QRA10.C**

Only in conjunction with ancillary unit AGQ3.xA27.

Refer to Data Sheet N7712



#### Ionization probe

Flame detector for use with Siemens burner controls for the supervision of gas flames.

To be supplied by customer



**Accessories** (to be ordered separately) (continued)

**Service tools**

Optical Interface **OCI400**

Article no.: **BPZ:OCI400**

- Optical interface between burner control and PC
- Facilitates viewing and recording of setting parameters on site using the ACS410 PC software

Refer to Data Sheet N7614.



BC interface module **OCI410**

- Service tool between burner control and PC
- Facilitates viewing, processing, and recording setting parameters on site using the ACS410 software

Refer to Data Sheet N7616..

Article no.	Type	
<b>BPZ:OCI410.30</b>	<b>OCI410.30</b>	<ul style="list-style-type: none"> <li>• Heating engineer version (standard)</li> <li>• Parameter change possible for the 'Heating engineer' password level</li> </ul>
<b>BPZ:OCI410.31</b>	<b>OCI410.31</b>	<ul style="list-style-type: none"> <li>• OEM variant</li> <li>• Parameterization with ACS410 PC software</li> <li>• Parameter change possible for the 'OEM' password level</li> </ul>
<b>BPZ:OCI410.40</b>	<b>OCI410.40</b>	<ul style="list-style-type: none"> <li>• OEM variant</li> <li>• Parameter change possible for the 'OEM and heating engineer' password level</li> </ul>



PC Software **ACS410**

Article no.: **BPZ:ACS410**

PC software for parameterization and visualization of the burner control.

On request.

Refer to Software Documentation J7352.



**OCI460** cloud gateway

Climatix IC communication gateway and Modbus interface with galvanic separation for burner controls, burner management systems, or flame safeguards equipped with Modbus or BC interface communication.

Refer to Data Sheet N7600.

**OCI460.10**

Article no.: **S55666-J401-A100**

- European variant

**OCI460.11**

Article no.: **S55666-J402-A100**

- Chinese variant



**Actuators**

Actuator **SQL3**  
Refer to Data Sheet N7808.



Actuator **SQL7**  
Refer to Data Sheet N7804.



Actuator **SQL9**  
Refer to Data Sheet N7806.



**Display and operating units**

Display and operating unit **AZL21.00A9**  
Article no.: **BPZ:AZL21.00A9**  
Separate unit, choice of mounting methods, 8-digit LCD, 5 buttons, BC interface for LME39, degree of protection IP40.  
Refer to Data Sheet N7542.



Display and operating unit **AZL23.00A9**  
Article no.: **BPZ:AZL23.00A9**  
Separate unit, choice of mounting methods, 8-digit LCD, 5 buttons, BC interface for LME39, degree of protection IP54.  
Refer to Data Sheet N7542.



## Accessories (to be ordered separately) (continued)

### Others

Valve proving system **LDU11** (only LME39.100Cx)  
Designed to check the tightness of shutoff valves in connection with gas burners and gas devices. In the event of inadmissible leakage, the system prevents the burner from starting up.  
Refer to Data Sheet N7696.



RC unit **ARC466890660**  
Article no.: **BPZ:ARC466890660**  
For the supervision of ionization currents in networks with non-earthed neutral conductor



PTC resistor **AGK25**  
Article no.: **BPZ:AGK25**

- AC 230 V
- To burden terminal 3 (for burners without fan motor such as atmospheric gas burners)



Ancillary unit **AGQ3.xA27**  
For UV supervision. Can be fitted under the plug-in base.



Article no.	Type	Cable length (mm)
<b>BPZ:AGQ3.1A27</b>	<b>AGQ3.1A27</b>	500
<b>BPZ:AGQ3.2A27</b>	<b>AGQ3.2A27</b>	300

Reset button extension **AGK20**  
For more details, refer to chapter *Dimensions*.



Signal cable **AGV50.100**  
Article no.: **BPZ:AGV50.100**  
For AZL2 display and operating unit, with RJ11 connector, cable length 1 m, pack of 10. Every AZL2 display and operating unit must come complete with a cable to connect it to the LME39.



## Technical data

### General unit data

Mains voltage	
<ul style="list-style-type: none"> <li>LME39.100C1/LME39.400C1</li> <li>LME39.100C2/LME39.400C2</li> </ul>	AC 120 V +10%/-15% AC 230 V +10%/-15%
Mains frequency	50...60 Hz
Power consumption	12 VA
External primary fuse (Si)	6.3 A (slow)



#### Caution!

#### Risk of damage to the switching contacts!

If the external primary fuse (Si) is blown due to overload or short-circuit at the terminals, the LME39 must be replaced.

Perm. mounting position	Optional
Input current at terminal 12	Max. 5 A
Weight	Approx. 160 g
Safety class I (burner control with plug-in base)	For applications without safe separation. Protection against electric shock is achieved through double or reinforced insulation. Provision for the protective earth connection is made in the plug-in base AGK11.6.
Type of shutdown or interruption for each circuit	Shutdown with micro switch, 1-pole Mode of operation type 2 B
Degree of protection	IP40 (if RJ11 jack is not covered, only IP10)



#### Note

The burner or boiler manufacturer must ensure degree of protection IP40 through adequate installation of the LME39.

Creepage distances and air gaps	<ul style="list-style-type: none"> <li>Overtoltage category III</li> <li>Rated surge voltage 4 kV at 230 V AC</li> <li>Pollution degree 2</li> <li>Up to 2,000 m above sea level</li> </ul>
Software class	Class C 2-channel structure
Reaction time in the event of loss of flame	Max. 1 s
Perm. cable length terminal 1	Max. 1 m at a line capacitance of 100 pF/m, unshielded (max. 3 m at 15 pF/m)
Perm. cable length from QRA2 / QRA2(1) / QRA2(2) / QRA2.9 / QRA4.U / QRA10.C to AGQ3.xA27 (lay separate cable) Multicore cables are not permitted.	Max. 20 m at 100 pF/m, unshielded
Remote lockout reset laid separately	Max. 20 m at 100 pF/m, unshielded
Perm. cable length terminals 8, 10 and 11	Max. 20 m at 100 pF/m, unshielded (lay separate cable)
Perm. cable lengths remaining terminals	Max. 3 m at 100 pF/m, unshielded
Perm. input voltage terminals 6 and 11	AC 120 V +10%/-15% AC 230 V +10%/-15%
Possible input current terminals 6	0.5 mA
Possible input current terminals 8 and 11	1 mA

## Technical data (cont'd)

Perm. current rating	At $\cos\varphi \geq 0.6$	At $\cos\varphi = 1$
Terminal 3	Max. 2.7 A (15 A for max. 0.5 s)	Max. 3 A
Terminals 4, 5 and 7	Max. 1.7 A	Max. 2 A
Terminal 9		
• LME39.100Cx	Max. 1 A	Max. 1 A
• LME39.400Cx	Max. 1.7 A	Max. 2 A
Terminal 10	Max. 1 A	Max. 1 A

Signal cable AGV50  
AZL2 / OCI410 → BC  
interface

<b>Signal cable</b>	Color white Unshielded Conductor 4 x 0.141 mm <sup>2</sup> with RJ11-connector
Cable length of the AGV50 signal cable	1 m
Location	Under the burner hood (additional measures necessary for protection class II)

Environmental conditions

<b>Storage</b>	EN 60721-3-1:1997
Climatic conditions	Class 1K3
Mechanical conditions	Class 1M2
Temperature range	-20...+60 °C
Humidity	<95% r.h.
<b>Transport</b>	EN 60721-3-2:1997
Climatic conditions	Class 2K3
Mechanical conditions	Class 2M2
Temperature range	-20...+60 °C
Humidity	<95% r.h.
<b>Operation</b>	EN 60721-3-3:1995 + A2:1997
Climatic conditions	Class 3K3
Mechanical conditions	Class 3M3
Temperature range	-20...+60 °C
Humidity	<95% r.h.
Installation altitude	Max. 2,000 m above sea level



### Attention!

**Condensation, formation of ice and ingress of water are not permitted!**  
**If this is not observed, there is a risk of loss of safety functions and a risk of electric shock.**

**AGK11.6 plug-in  
base**

<b>Connectable conductor cross-sections</b>	
• Terminals 1...12	Min. 0.5 mm <sup>2</sup> Max. 1.5 mm <sup>2</sup> Wire or stranded wire with ferrules
• Auxiliary terminals N, PE, 31, 32	Min. 0.5 mm <sup>2</sup> Max. 1.5 mm <sup>2</sup> Wire or stranded wire with ferrules (when connecting 2 wires or stranded wires per terminal, the same cross- sectional areas must be used for each terminal)

**Flame supervision with ionization probe**

	At mains voltage	
	UN = AC 120 V <sup>1)</sup>	UN = AC 230 V <sup>1)</sup>
Detector voltage between ionization probe and ground (AC voltmeter $R_i \geq 10 \text{ M}\Omega$ )	AC 50...120 V	AC 115...230 V
Switching threshold (limit values):		
Switching on (flame on) (DC ammeter $R_i \leq 5 \text{ k}\Omega$ )	$\geq \text{DC } 1.5 \mu\text{A}$	$\geq \text{DC } 1.5 \mu\text{A}$
Switching off (flame off) (DC ammeter $R_i \leq 5 \text{ k}\Omega$ )	$\leq \text{DC } 0.5 \mu\text{A}$	$\leq \text{DC } 0.5 \mu\text{A}$
Detector current required for reliable operation	$\geq \text{DC } 3 \mu\text{A}$	$\geq \text{DC } 3 \mu\text{A}$
Switching threshold in the event of poor flame during operation (signal lamp (LED) flashes green)	Approx. DC 5 $\mu\text{A}$	Approx. DC 5 $\mu\text{A}$
Short-circuit current between ionization probe and ground (AC ammeter $R_i \leq 5 \text{ k}\Omega$ )	AC 50...150 $\mu\text{A}$	AC 100...300 $\mu\text{A}$
Possible detector current during operation	Max. 20 $\mu\text{A}$	Max. 20 $\mu\text{A}$

<sup>1)</sup> For applications outside the European Community, operation at mains voltage AC 120 V / AC 230 V  $\pm 10\%$  is ensured

Flame supervision via ionization is accomplished by making use of the conductivity and rectifying effect of the flame.

The DC current that flows in the presence of a flame (ionization current) is largely proportional to the flame quality. This current is measured in the flame signal amplifier.

The amplifier is designed such that it only responds to the DC current component of the flame signal. This ensures that a short circuit between the ionization probe and ground cannot simulate a flame signal (since in that case AC current would flow).

**Note!**

The ignition (ignition spark) can have a negative effect on the ionization current formation during startup.



To minimize the impact

- the positioning of the ionization probe must be checked and optimized
- it may be beneficial to replace the electrical connections (phase / neutral) on the primary side of the ignition transformer

A short-circuit between ionization probe and ground initiates a non-volatile lockout depending on the restart setting.

Measuring circuit

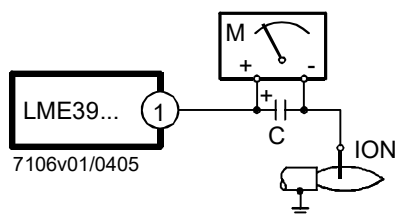

Legend

- C Electrolytic capacitor 100...470  $\mu\text{F}$ ; DC 10...25 V
- ION Ionization probe
- M Microammeter,  $R_i$  max. 5,000  $\Omega$

For detector currents, see *Technical Data*.

## Technical data (cont'd)

### Flame supervision with AGQ3.xA27 and flame detector QRA2 / QRA2(1) / QRA2(2) / QRA2.9 / QRA4.U / QRA10.C



Only in connection with LME39.100C2/LME39.400C2 (AC 230 V)!

#### Notes

Lifetime of the UV cell.

UV cells and the QRA2 / QRA2(1) / QRA2(2) / QRA2.9 / QRA4.U / QRA10.C are subject to wear and tear and must be replaced as part of regular maintenance, at the latest at the end of the average lifetime of the UV cell. The lifetime of the UV cell corresponds to approx. 10,000 hours at a maximum of +50°C; higher ambient temperatures reduce the lifetime considerably. For details, refer to chapter *Technical Data* in Data Sheet N7712 for the QRA2 / QRA2(1) / QRA2(2) / QRA2.9 / QRA10.C. For details, refer to chapter *Technical Data* in Data Sheet N7711 for the QRA4.U.

Mains voltage	AC 230 V +10%/-15%
Mains frequency	50...60 Hz ±6%
Perm. cable length from QRA2 / QRA2(1) / QRA2(2) / QRA2.9 / QRA4.U / QRA10.C to AGQ3.xA27 (lay separate cable) Multicore cables are not permitted.	Max. 20 m, unshielded
Perm. cable length from AGQ3.xA27 to LME39.100C2/LME39.400C2	Max. 2 m, unshielded
Weight of AGQ3.xA27	Approx. 140 g
Perm. mounting position	Optional
Degree of protection	IP40, to be ensured through mounting
Power consumption	4.5 VA

	At mains voltage UN	
	AC 220 V	AC 240 V
<b>Detector voltage at QRA2 / QRA2(1) / QRA2(2) / QRA2.9 / QRA4.U / QRA10.C (with no load)</b>		
Terminal 3 OFF (see <i>Program sequence</i> )	DC 400 V	DC 400 V
Terminal 3 ON (see <i>Program sequence</i> )	DC 300 V	DC 300 V
<b>Detector voltage Load by DC measuring instrument Ri &gt;10 MΩ</b>		
Terminal 3 OFF (see <i>Program sequence</i> )	DC 380 V	DC 380 V
Terminal 3 ON (see <i>Program sequence</i> )	DC 280 V	DC 280 V
<b>DC current detector signals with QRA2 / QRA2(1) / QRA2(2) / QRA2.9 / QRA4.U / QRA10.C</b>	<b>Min. required</b>	<b>Max. possible</b>
Measurement on the QRA2 / QRA2(1) / QRA2(2) / QRA2.9 / QRA4.U / QRA10.C	200 µA	500 µA

## Technical data (cont'd)

### Ancillary unit AGQ3.xA27

Use of the AGQ3.xA27 ancillary unit is mandatory in connection with LME39 burner controls.

A UV test with increased supply voltage is performed to check the through-ignition tendency of aging UV tubes. The UV test is performed in standby until the fan motor (terminal 3) is activated, refer to chapter *Program sequence*.

#### Connection diagram

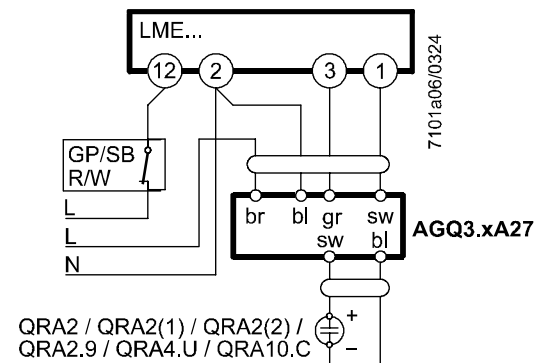

#### Measuring circuit for measuring the UV detector current

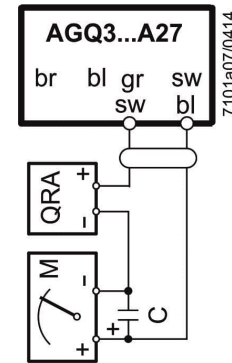

Measurement made at the flame detector QRA2 / QRA2(1) / QRA2(2) / QRA2.9 / QRA4.U / QRA10.C

#### Legend

C	Electrolytic capacitor 100...470 $\mu$ F; DC 10...25 V	bl	Blue
M	Microammeter $R_i$ max. 5,000 $\Omega$	br	Brown
QRAx	UV flame detector QRA2 / QRA2(1) / QRA2(2) / QRA2.9 / QRA4.U / QRA10.C	gr	Grey (old: rt = red)
GP	Pressure switch	sw	Black
SB	Safety limit thermostat		
R	Control thermostat or pressurestat		
W	Limit thermostat or pressure switch		

Program sequence LME39.100Cx

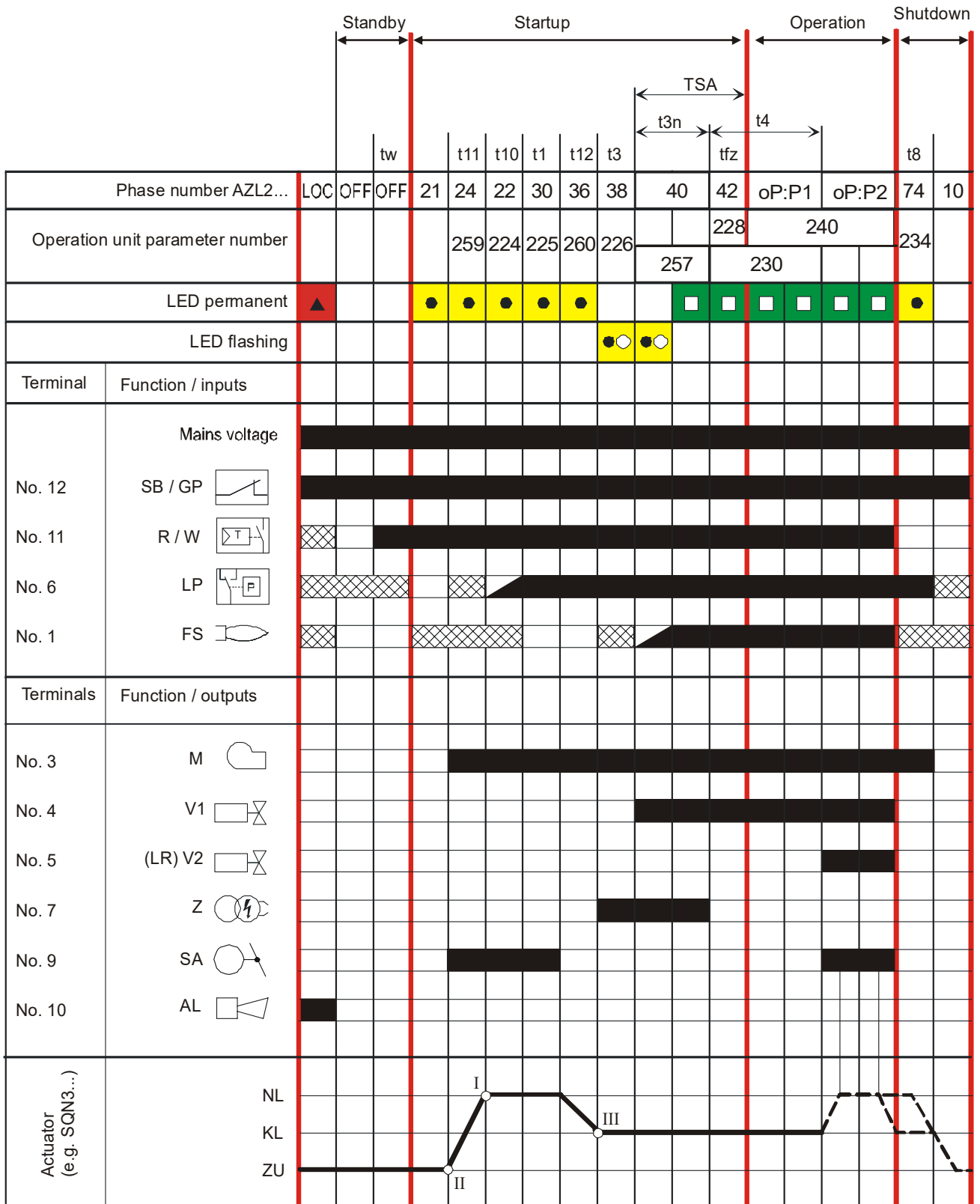

7106d04e/0312

Inputs and outputs/internal connection diagram LME39.100Cx

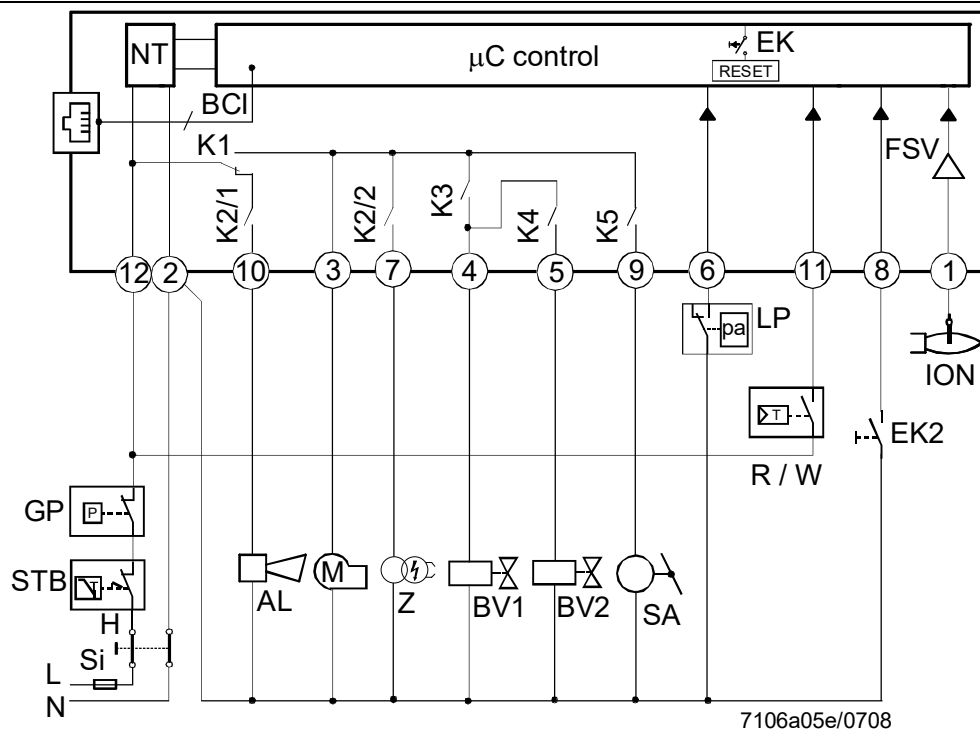

**Caution!**  
 Risk of damage to the switching contacts!  
 If the external primary fuse (Si) is blown due to overload or short-circuit at the terminals, the LME39 must be replaced.

## Application examples



### Attention!

The connection diagrams shown are merely examples which must be adapted in the individual case depending on the application!

Control of actuators of 2-stage or 2-stage modulating burners.  
Controlled prepurging (t1) with high-fire air volume.

For information about actuators:

SQN3 see Data Sheet N7808

SQN7 see Data Sheet N7804

SQN9 see Data Sheet N7806

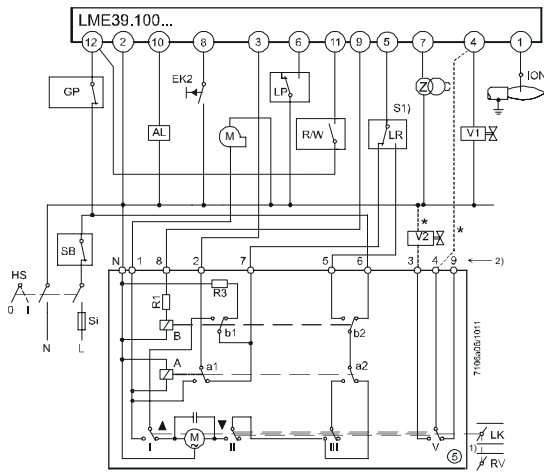
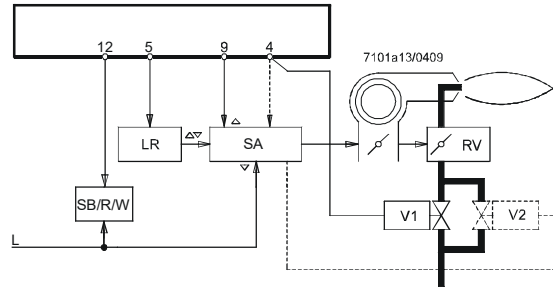

**SQN3x.151xx or SQN3x.251xx**

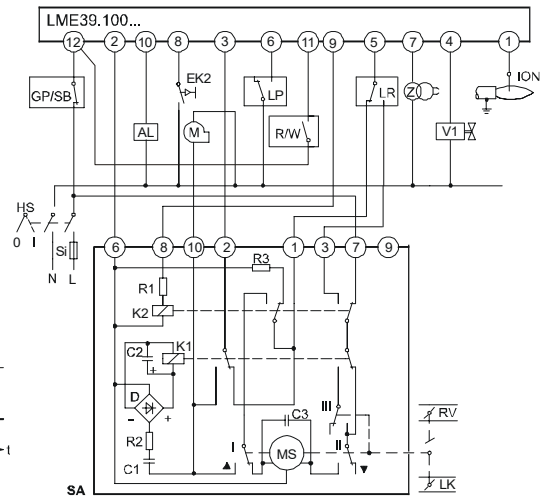

**SQN90.220xx/2-stage modulating control**



### \* Note!

With 2-stage modulating burners (with gas regulation damper (RV), fuel valve (V2) and the dotted connection between terminals (\*) are not required.

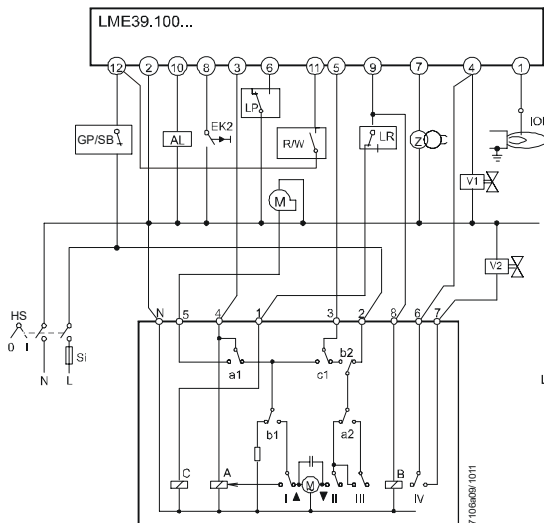

**SQN7x.454xx/2-stage control  
1 wire control**

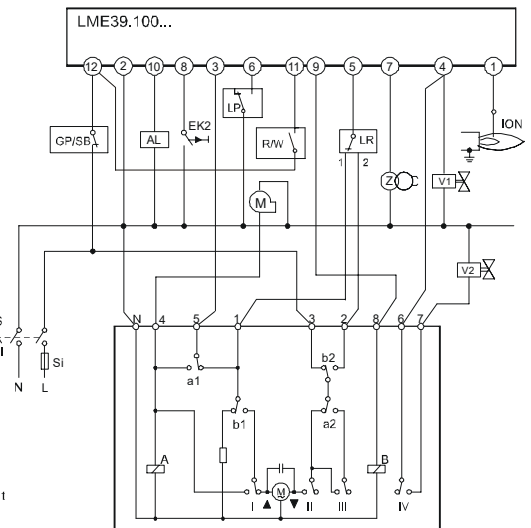
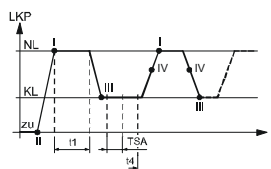

**SQN7x.424xx/2-stage control  
2 wire control**



### Caution!

**Risk of damage to the switching contacts!**

If the external primary fuse (Si) is blown due to overload or short-circuit at the terminals, the LME39 must be replaced.

**LME39.100Cx with LDU11 valve supervision system**

- Valve supervision before commissioning of burner
- In the case of plants without vent pipe to atmosphere

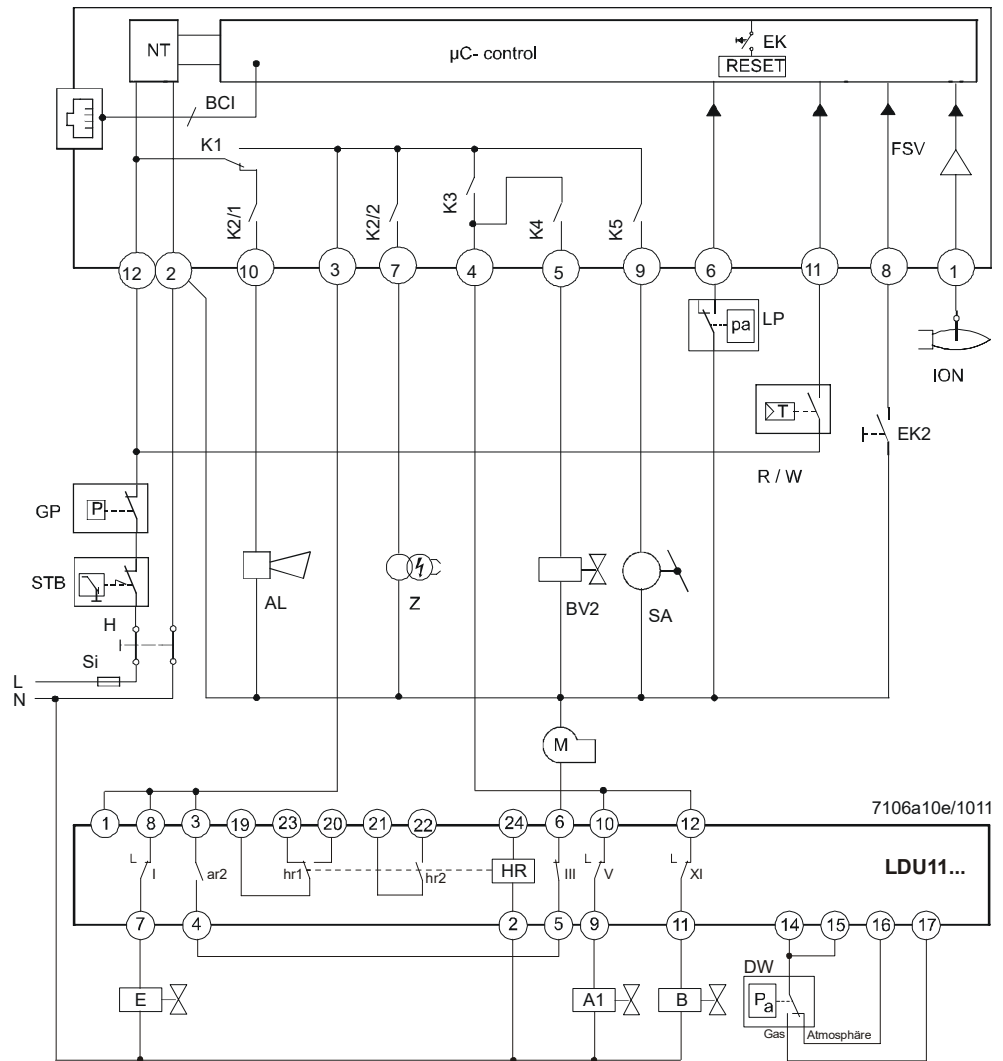

**Caution!**  
**Risk of damage to the switching contacts!**  
 If the external primary fuse (Si) is blown due to overload or short-circuit at the terminals, the LME39 must be replaced.



- Valve proving is started each time the system is switched on, with connection of terminal 3, after controller ON or after lockout
- If the LDU11 initiates lockout, valve proving can take up to 160 seconds. Therefore, the maximum permissible response time of the air pressure switch is 180 seconds
- Errors during valve proving lead to a lockout with the LDU11, and to a non-volatile lockout with the LME39.100Cx due to an air pressure switch timeout (blink code 3)



- **Note!**  
 A faulty air pressure switch (air pressure switch does not close) leads to a non-volatile lockout (blink code 3) on completion of the air pressure switch response time of 180 seconds and can only be distinguished from a non-volatile lockout in the event of faulty valve proving by the fact that there is no LDU11 lockout
- The fan motor must be connected to terminal 6 of the LDU11 since release takes place via the air pressure switch upon successful valve proving

Program sequence LME39.400Cx

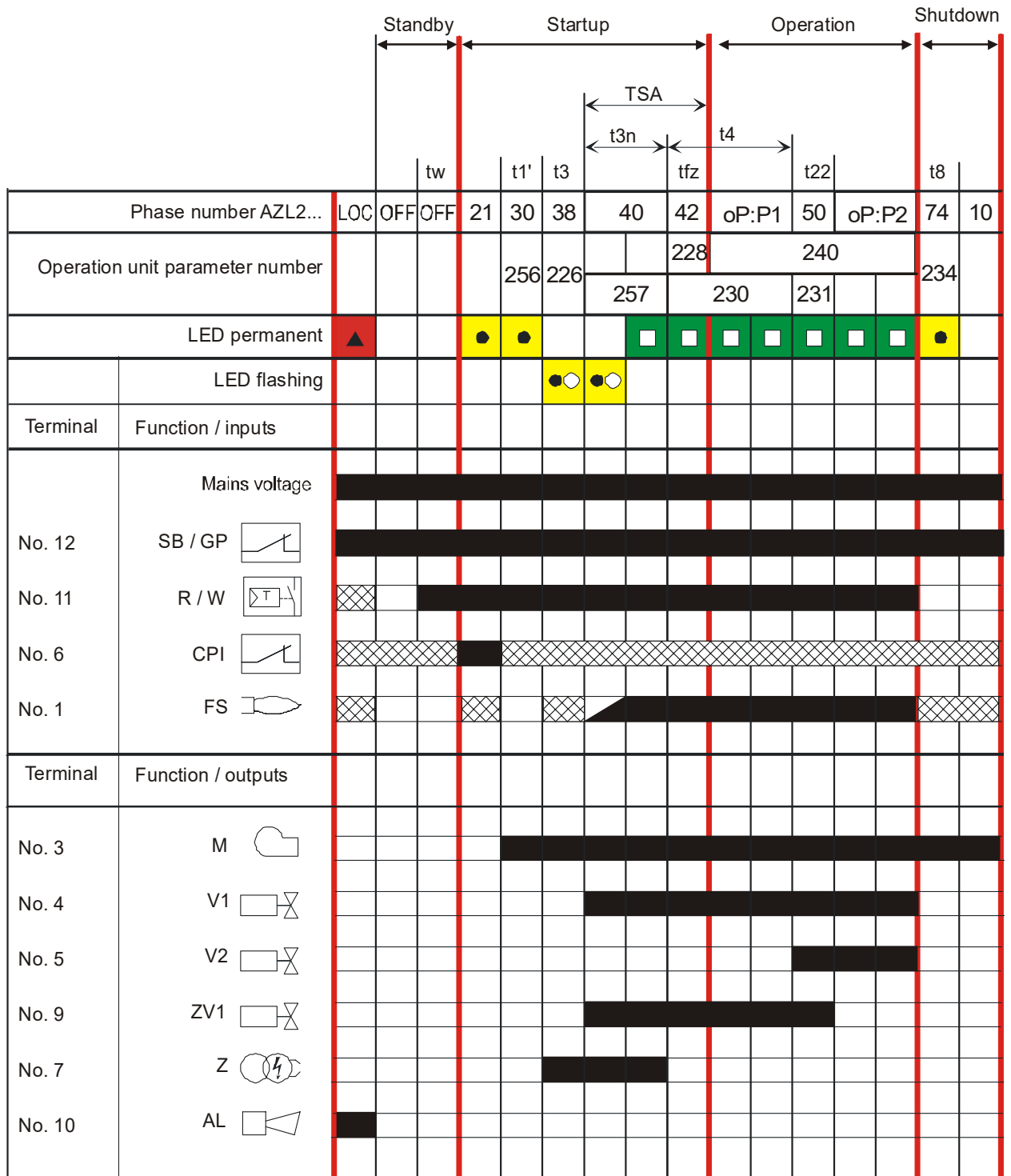

7106d05e/0312

Inputs and outputs/internal connection diagram LME39.400Cx

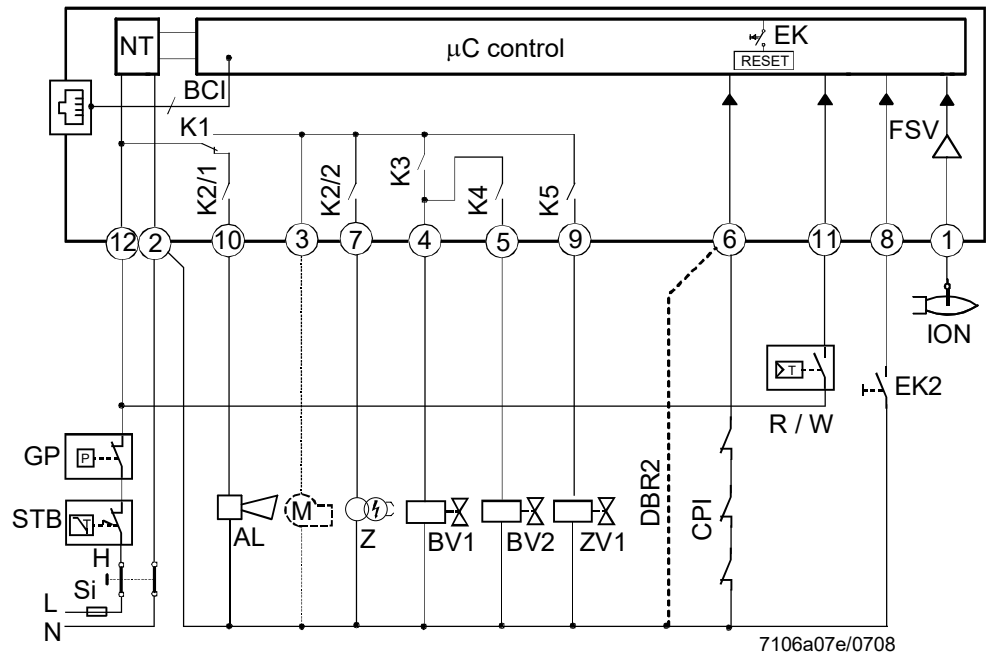

**Caution!**  
**Risk of damage to the switching contacts!**  
 If the external primary fuse (Si) is blown due to overload or short-circuit at the terminals, the LME39 must be replaced.

Application examples



**Attention!**  
 The connection diagram shown is merely an example which must be adapted in the individual case depending on the application!

Recommendation:



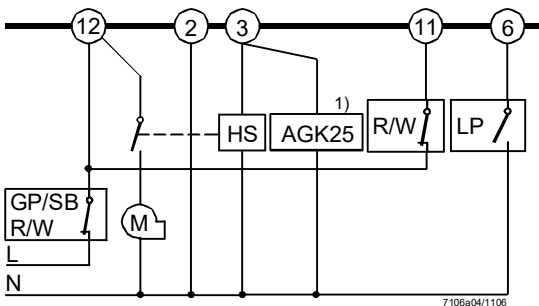

**Note**  
 In environments with high electromagnetic interference, terminal 3 should be loaded with the AGK25 PTC resistor for burners without a fan motor or for fan control with an auxiliary contactor, otherwise the burner will not start reliably.



1) AGK25 PTC resistor only required for an auxiliary with a coil resistance of  $\geq 50 \text{ k}\Omega$

## Legend

A, A1, A2	Gas valves controlled to evacuate the test space with valve proving
AGK25	PTC resistor
AL	Error message (alarm)
B	Gas valve controlled to fill the test space with valve proving
BCI	Communication interface
CPI	Closed Position Indicator
DBR2	Wire link
DW	Pressure switch - valve proving
E	Safety shut-off valve, dead closed (optional)
EK	Lockout reset button (internal)
EK2	Remote lockout reset button
FS	Flame signal
FSV	Flame signal amplifier
GP	Gas pressure switch
H	Main switch
HS	Auxiliary contactor, relay
ION	Ionization probe
K1...5	Internal relay
KL	Low-fire
LK	Air damper
LKP	Air damper position
LP	Air pressure switch
LR	Load controller
M	Fan motor
MS	Synchronous motor
NL	High-fire
NT	Power supply unit
QRAx	UV flame detector QRA2 / QRA2(1) / QRA2(2) / QRA2.9 / QRA4.U / QRA10.C
R	Control thermostat / pressurestat
RV	Gas regulation damper
SA	Actuator SQN
SB	Safety limiter
STB	Safety limit thermostat
Si	External pre-fuse
t	Time
Vx	Fuel valve
W	Limit thermostat / pressure switch
Z	Ignition transformer
ZV	Extra valve
I, II, III	Cam actuator
t1	Purge time
t1'	Purge time
t3	Preignition time
t3n	Postignition time (parameter 257+0.3 seconds)
t4	Interval between ignition OFF and release of fuel valve 2
t8	Postpurge time
t10	Specified time for air pressure signal
t11	Programmed opening time for actuator
t12	Programmed closing time for actuator
t22	2nd safety time
tfz	Flame detection time
TSA	Ignition safety time (t3n + tfz)
tw	Waiting time
	Input signal/output signal 1 (ON)
	Input signal/output signal 0 (OFF)
	Input permissible signal 1 (ON) or 0 (OFF)

## Dimensions

Dimensions in mm

LME39



Plug-in base AGK11.6

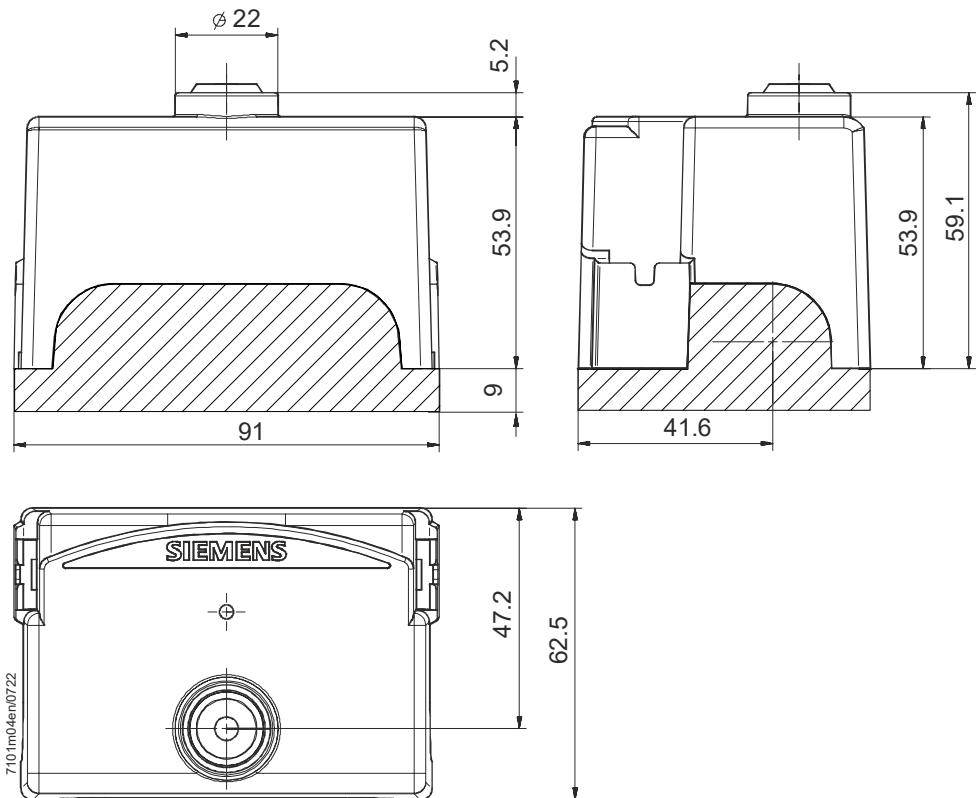

LME39 with lockout reset  
button extension AGK20

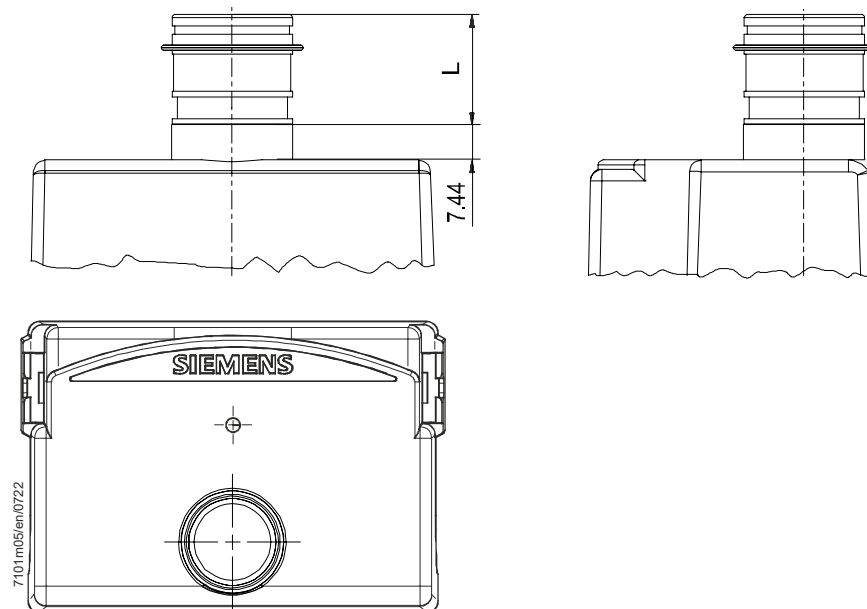

Designation	Length (L) in mm
AGK20.19	19
AGK20.43	43
AGK20.55	55

**Dimensions (cont'd)**

Dimensions in mm

Ancillary unit AGQ3.xA27

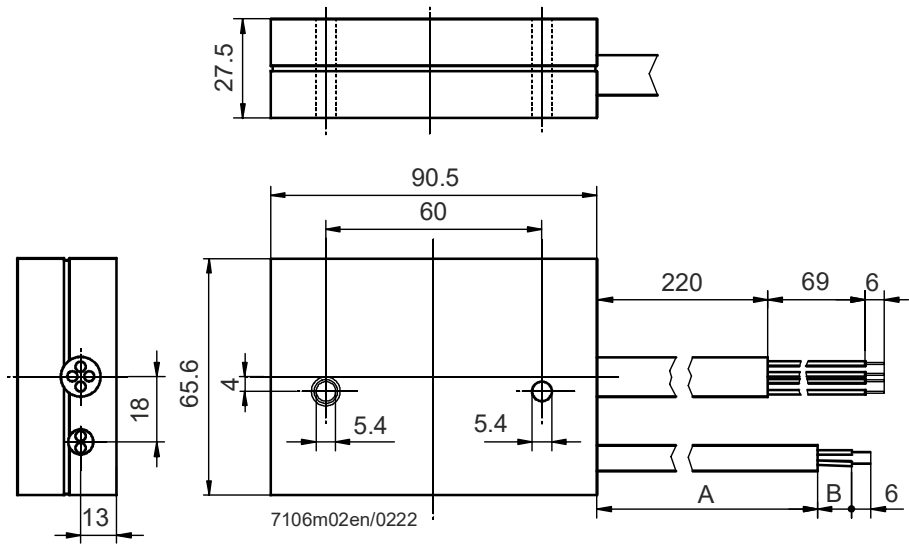

Type	Dimensions	
	A	B
AGQ3.1A27	500	19
AGQ3.2A27	300	34

© 2024 Siemens AG Smart Infrastructure, Berliner Ring 23, D-76437 Rastatt  
Subject to change!