

Encoder

Profibus-DP Interface Absolute Singleturn Encoder EAC58



Description

Profibus-DP interface absolute singleturn encoder EAC58 series provides outstanding performance in withstanding mechanical damages and higher axial and radial loads. Various types of flanges are available to meet different requirements. The series complies with Profibus protocol, and its maximum resolution is up to 8192. Its high speed communication and anti-interference deliver strong and stable operation.

Features

- Various types of flanges are available
- Pre-screwed holes are convenient for installation
- Waterproof seal provides greater IP level
- Direct cable output, which is convenient for installation and maintenance
- Protection class IP65
- Metal housing for better shock resistance
- Conforming to Profibus-DP protocol

Mechanical Characteristics

Shaft diameter (mm)	Φ6g6	-58B
	Φ8g6	-58A/B
	Φ9.52(3/8")g6	-58A
	Φ10g6	-58C
Hollow shaft diameter (mm)	Φ8H7/Φ9.52H7/Φ10H7	-58/W
	Φ12H7/Φ14H7/ Φ15H7	-58/W
Protection acc. to EN 60529	IP65	
Speed	6000, continuous	
Axial load capacity	80N	
Radial load capacity	160N	
Shock resistance	50G/11ms	
Vibration resistance	10G 10~2000Hz	
Bearing life	10 ⁹ revolution	
Rotor moment of inertia	approx.1.8×10 ⁻⁶ kgm ²	
Starting torque	<0.05Nm	
Body material	ALUNI 9002/5 -(D11S)	
Housing material	AL6060	
Flange material	ALUNI 9002/5 -(D11S)	
Operating temperature	-40 °C~~+80 °C	
Storage temperature	-45 °C~~+85 °C	
Weight	~800g	

Resolution 8192 4096

Electrical Characteristics

Resolution	8192 (13 bits)
Supply voltage	10~30 Vdc
Power consumption (no load)	300mA
Baud rate	12 Mbaud
Linearity	+/- 1/2 LSB
Output frequency	Max 100 KHz

Connection

+V	Supply voltage(24 VDC)
0V	Ground
A	Profibus-DP line output (GN)
B	Profibus-DP line output (RD)
A	Profibus-DP line input (GN)
B	Profibus-DP line input (RD)

Profibus-DP Interface Absolute Singleturn Encoder EAC58

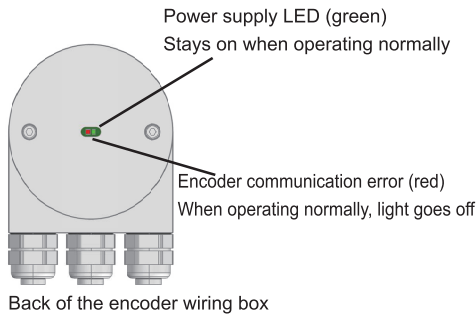

Back of the encoder wiring box

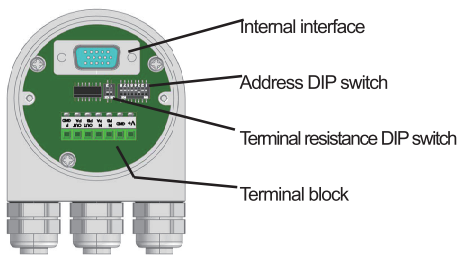

Inside of the encoder wiring box

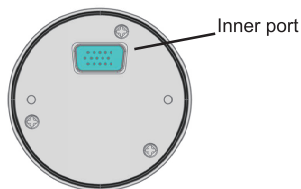

Back cover of the encoder

Address DIP switch Bit 8 is used for changing counter direction. Bit 1 to Bit 7 is used to set up the encoder address. A Profibus network can accept up to 126 addresses.

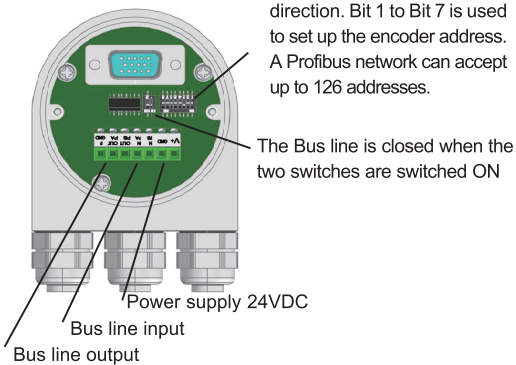

The Bus line is closed when the two switches are switched ON

Power supply 24VDC

Bus line input

Bus line output

Introduction

Profibus-DP interface absolute singleturn encoder (Identification number 0x0CCA) conforms to the Profibus-DP standard as described on the European Standard EN 50170 Vol. 2. The encoders are designed according to "Profibus Profile for Encoders, Order No. 3062".

The Profibus-DP interface has the same maximum resolution and features (8192 position/revolution) of the stand-alone version, and it also has the advantages of the Profibus-DP network. Through the Profibus-DP network is possible to:

- During the periodic data exchange, obtaining the angular position from the encoder.
- Resolution and the revolution are configurable now (please refer to the corresponding chapters for configuring the parameters).
- Changing the default increment count direction (change between CW/CCW when configuring the parameters).
- Perform the Preset operation (Set the encoder to read a specific position).
- Read the diagnosis status.
- Getting info about the code supplied by the device.

From the device it is possible to:

- Display the ON/OFF status.
- Display the device activity on the bus.
- Activate the Reset function
- Set up the device address.
- If required, insert the terminal resistance into the bus.
- Change the counting direction

Installation

Installing the Profibus-DP encoder in a network requires the execution of the standard procedures necessary for configuring any Profibus-DP slave. The procedures are as follows:

- 1- Add the slave onto the master (please see corresponding chapter).
- 2- Wire the encoder into the Profibus network. Whether wiring it in the middle or at the terminal are depending on the physical position the device has in the bus.
- 3- Directly set up the address (which must be unique in the network and as the same as the device) for the slave.
- 4- Prepare the applications at the master side and set up the Profibus network.

On the back cover of the encoder there are two LED indicators. The device's operating status can be observed by the two LEDs. The green LED shows the power status and must be on constantly. The red LED only switches off during the periodic data exchange between the Profibus master and the encoder.

Note: To set and configure the slave into the Profibus-DP master, it is necessary to use the "gsd" file delivered with the encoder. The file can be found on the CD.

DIP-switch setup (configuring slave address)

Besides the address and the standard position of a terminal DIP switch, a configuration example of Profibus and the devices is illustrated below.

In this example, device's address is set up as 1001101, with the corresponding decimal address as 77. Bit 7 is the top digit, and bit 1 is the lowest digit. Bit 8 is used for changing the counter direction. Bit 1 to bit 7 are used to configure encoder's address.

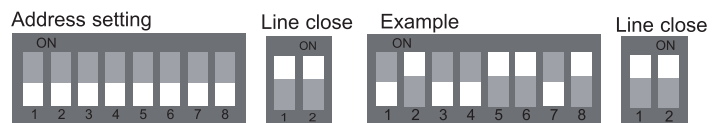

Network Characteristics

Usually, an A type cable is used to wire a DP/FMS network. This cable has to have the following characteristics:

Parameter	A type cable
Characteristic resistance (Ω)	135...165 at a certain frequency (3...20Mhz)
Rated capacity (PF/m)	<30
Loop resistance (Ω /Km)	<=110
Core diameter (mm)	>0.64*
Core cross-section (mm^2)	>0.34*

This cable allows the optimal network utilization. In fact, it is possible to reach the maximum communication speed allowed (12Mbaud). However, there are some limitations due to the maximum physical dimensions of a bus segment as follows:

kbaud	9.6	19.2	93.75	187.5	500	1500	12000
Range/Segment	1200m	1200m	1200m	1000m	400m	200m	100m

Finally, the physical characteristics of a Profibus network are learned.

Encoder

Encoder

Profibus-DP Interface Absolute Singleturn Encoder EAC58

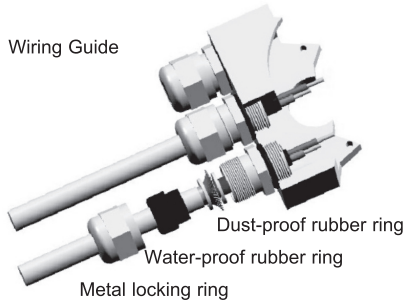

Max. number of station participating in the exchange of user data	DP: 126 (Address 0-125) FMS: 127 (Address 0-126)
Max. number of stations per segment	32
Available data transfer rates (kbit/s)	9.6,19.2,45.45,93.75,187.5,500,1500,3000,
Max. segments	6000,12000

According to EN50170, a maximum of 4 repeaters are allowed between any two stations. Dependent on the repeater type and manufacturer, more than 4 repeaters may be allowed in some cases. Refer to the manufacturer's technical specification for details.

Wiring box

Unscrew the back cover, and wire the cables (power cable, input and output bus) according to the instructions on the cover. The cable will pass through the metallocking ring, water-proof rubber ring, and dust-proof rubber ring into the metal notch. Lock the metal ring to fasten the cables

Dimensions

EAC58A

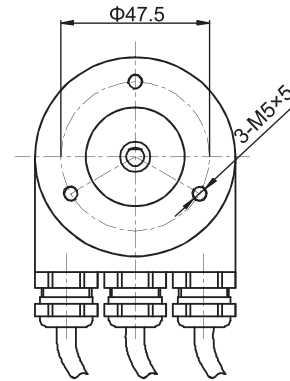
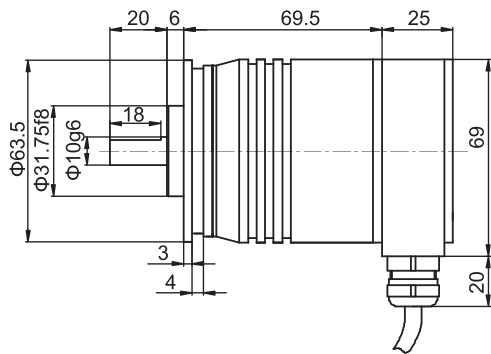

EAC58B

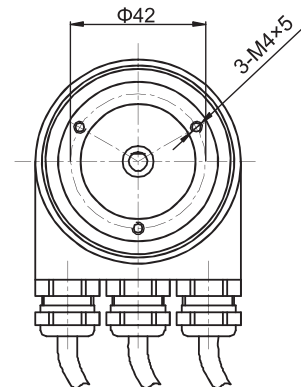
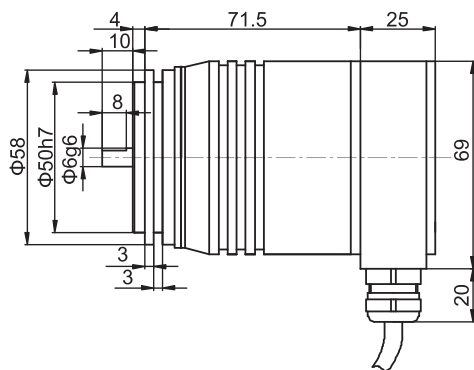

Profibus-DP Interface Absolute Singleturn Encoder EAC58

Dimensions

EAC58C

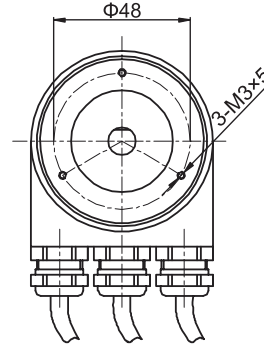
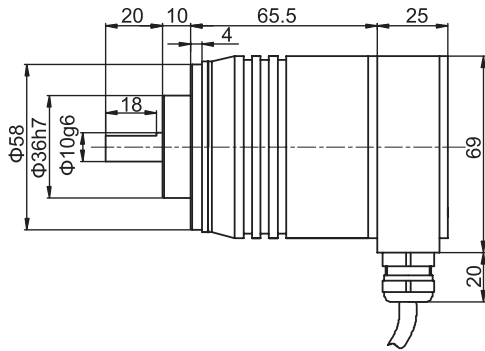

EAC58W

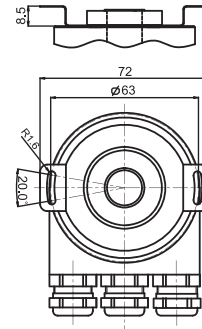
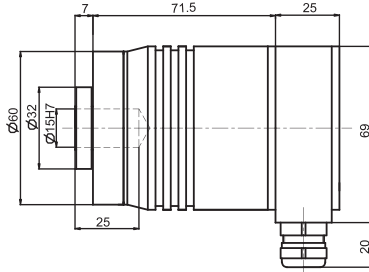

Encoder

Encoder

Profibus-DP Interface Absolute Singleturn Encoder EAC58

Order Code:

